

ASSEMBLY INSTRUCTIONS FOR CMP SERIES COVERS

1 - Select the tightest insert that will fit over the cable. If a very tight fit is not encountered, one of the following may be tried.

- a) Heat the cable to increase its flexibility.
- b) Cut through one side of the insert.
- c) Moisten the outer cable jacket to lubricate.

2a - Braided Cable: Remove outer cable jacket until even with the small end of the compression insert and cut off excess braid. Fold back the braid over the compression insert to ensure braid seats under compression stops.

2b - Foil Shield Cable: Cut two parallel slits in the jacket. Carefully remove the jacket and fold foil back over the compression insert and trim even with the insert. If the drain wire is outside the foil (i.e. if the conducting side of the foil is on the outside), fold the foil twice so that the conductor is against the connector cover. Only a small area of the foil shield is required to make contact with the compression insert stops to ensure effective shielding.

3 - Install long thumbscrews if used.

4 - Install connector and close cover using a slot screw driver.

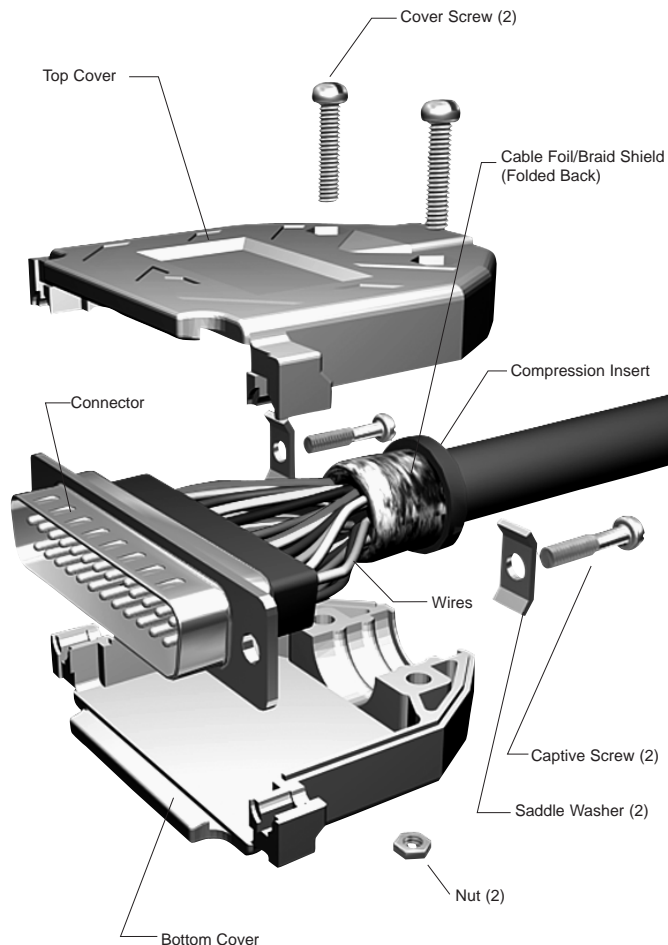

CROSS SECTION OF NorTech™ COMPRESSION INSERT SYSTEM

