

Northern Technologies

ASSEMBLY INSTRUCTIONS FOR METAL HD COVERS

STRIP OUTER JACKET TO EXPOSE BRAID/FOIL. SELECT AN INSERT WITH AN I.D. THAT TIGHTLY FITS THE CABLE JACKET. SLIDE INSERT OVER JACKET (Fig. 1)

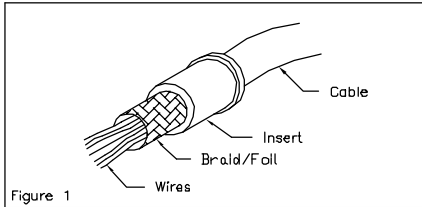

Figure 1

* STRIP LENGTH WILL VARY WITH DIFFERENT INSERT I.D.'S *

CUT TWO SLITS ALONG BRAID/FOIL. (Fig. 2)

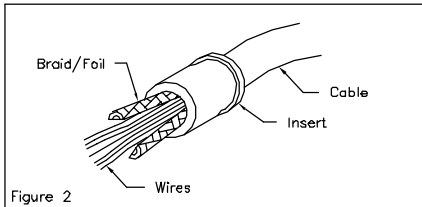

Figure 2

FOLD BRAID/FOIL OVER THE INSERT. (Fig. 3)

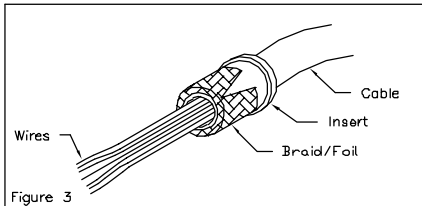

Figure 3

PLACE THE INSERT INTO THE BOTTOM CAVITY OF COVER. PLACE ASSEMBLED CONNECTOR INTO THE CAVITY OF THE BOTTOM COVER. (Fig. 4)

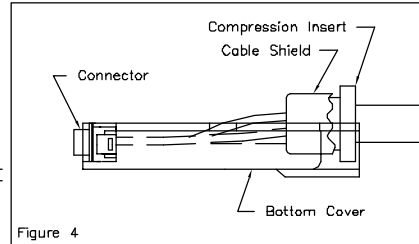

Figure 4

WITH THE INSERT AND CONNECTOR IN PLACE, THE TOP OF THE COVER MAY BE SECURED TO THE BOTTOM COVER. (Fig. 5)

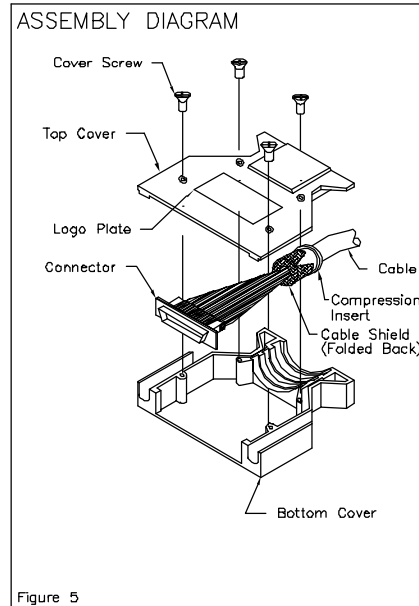



Figure 5

REV	DATE	DESCRIPTION OF CHANGE	APP
	22-SEP-94	INITIAL RELEASE	

THIS DRAWING IS THE PROPERTY OF NORTHERN TECHNOLOGIES AND SHOULD NOT BE REPRODUCED WITHOUT NORTHERN TECHNOLOGIES WRITTEN PERMISSION.

PART NO: N/A		DESCRIPTION: ASSY INSTRUCTIONS FOR METAL HD COVERS	
APPROVALS	DATE		
DRN: JSD	22-SEP-94		
CHK'D: SCN	22-SEP-94		
DESIGN: J. DIPIETRO	20-SEP-94	DWG NO:	0002-080-035
TOLERANCES:	N/A	SCALE:	SHEET: 1 OF 1