

REV	DATE	DESCRIPTION	APP
A	19-APR-13	ECN 0719	

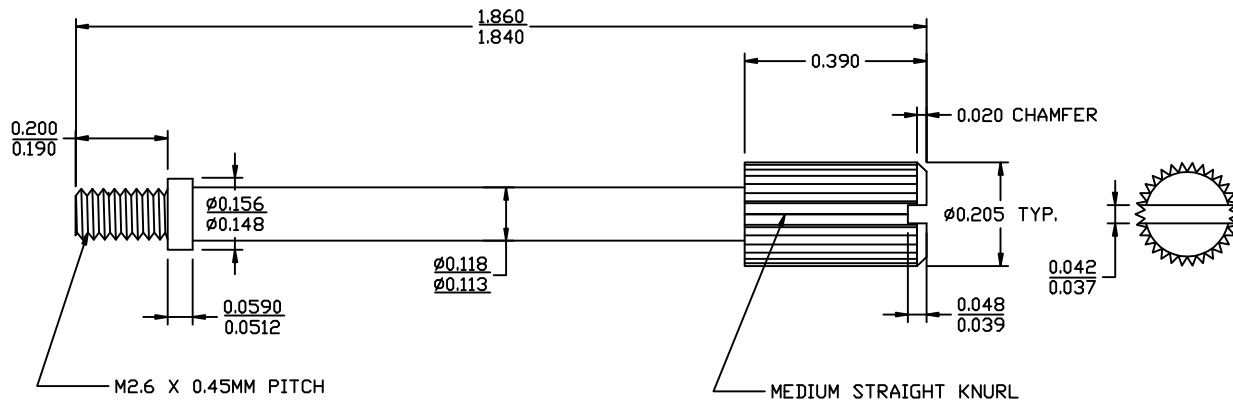

- NOTES:
1. MATERIAL: 12L14 LOW CARBON STEEL
 2. FINISH: CLEAR ZINC
 3. ALL DIMENSIONS IN INCHES
 4. TOLERANCE: ±0.005 UNLESS OTHERWISE STATED

UNLESS OTHERWISE SPECIFIED	SIGNATURES	DATE	Northern Technologies		THIS DRAWING IS THE PROPERTY OF NORTHERN TECHNOLOGIES AND SHOULD NOT BE REPRODUCED WITHOUT NORTHERN TECHNOLOGIES WRITTEN PERMISSION.
1. ALL DIMENSIONS ARE IN INCHES (MM) 2. DIMENSIONS ARE TYPICAL	DRAWN	JSD	21-MAY-08	PART NUMBER B71E014401M26Z	
	CHECKED	SCN	21-MAY-08	DESCRIPTION M2.6 X 1.85 T/SCREW Zn [RoHS]	
	ENG				
	ISSUED		21-MAY-08	SHEET 1	CODE 520_261M26Z
			SCALE N.T.S.		SHEET 1 OF 1

THIS IS A CONTROLLED DOCUMENT AND IS SUBJECT TO CHANGE. CONTACT NORTHERN TECHNOLOGIES ENGINEERING FOR THE LATEST REVISION.