

REV	DATE	DESCRIPTION	APPR.
A	20-NOV-14	ECN 0760	

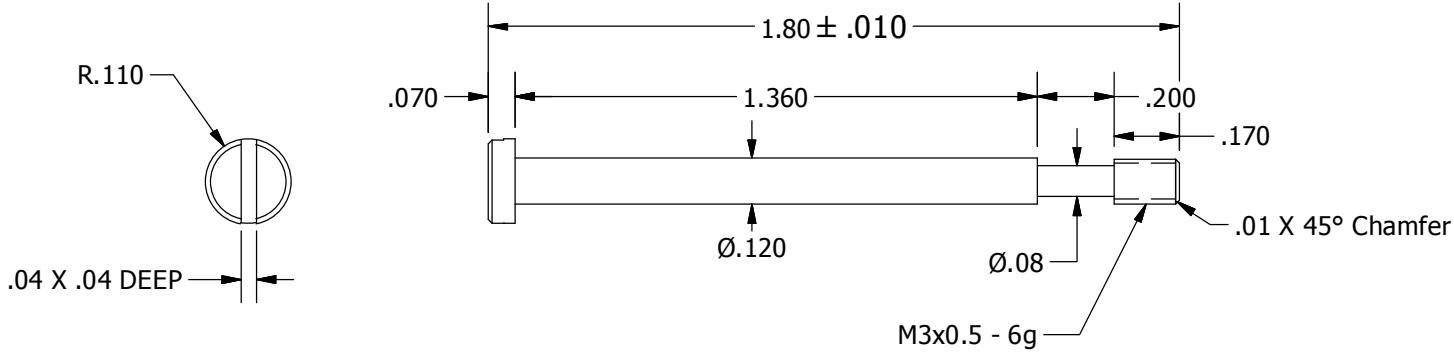

- NOTES:
1. MATERIAL: 12L14 STEEL OR EQUIV.
 2. FINISH: BRIGHT NICKEL PER AMS-QQ-N-290 CLASS 1, GRADE F OR EQUIVALENT
 3. TOLERANCE: UNLESS OTHERWISE SPECIFIED

DECIMALS	ANGLES
.XXX ± .005	± 2.0°
.XX ± .015	
 4. DIMENSIONS APPLY AFTER PLATING

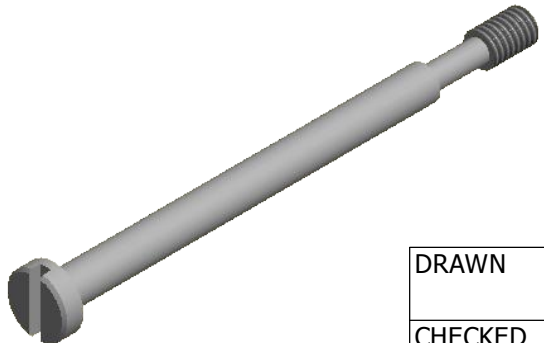

DRAWN	JSD	07-MAY-12
CHECKED	SCN	07-MAY-12
ISSUED		07-MAY-12

Northern Technologies

THIS DRAWING IS THE PROPERTY OF NORTHERN TECHNOLOGIES AND SHOULD NOT BE REPRODUCED WITHOUT NORTHERN TECHNOLOGIES WRITTEN PERMISSION.

PART NUMBER B71E024605M3
 DESCRIPTION M3 X 1.80 CMR KIT SCREW Ni

SIZE	CODE	DWG NO.	REV
A	520_236M3	0002-520-236M3	B
SCALE	N.T.S.	SHEET	1 OF 1

THIS IS A CONTROLLED DOCUMENT AND IS SUBJECT TO CHANGE. CONTACT NORTHERN TECHNOLOGIES ENGINEERING FOR THE LATEST REVISION.