

2

1

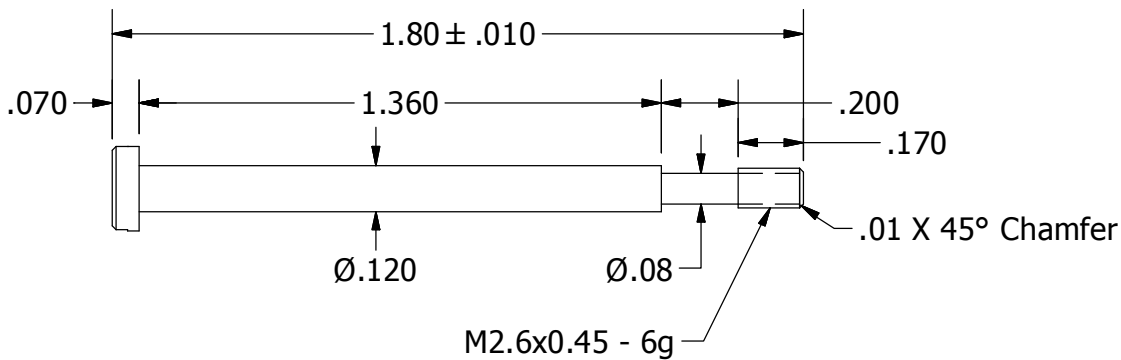
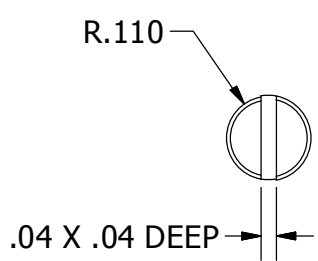

NOTES:

1. MATERIAL: 12L14 FREE-MACHING STEEL
2. FINISH: BRIGHT NICKEL PER AMS-QQ-N-290 CLASS 1, GRADE F OR EQUIVALENT
3. TOLERANCE: UNLESS OTHERWISE SPECIFIED  

DECIMALS	ANGLES
.XXX ± .005	± 2.0°
.XX ± .015	
4. DIMENSIONS APPLY AFTER PLATING
5. ALL MATERIALS USED MUST BE RoHS COMPLIANT

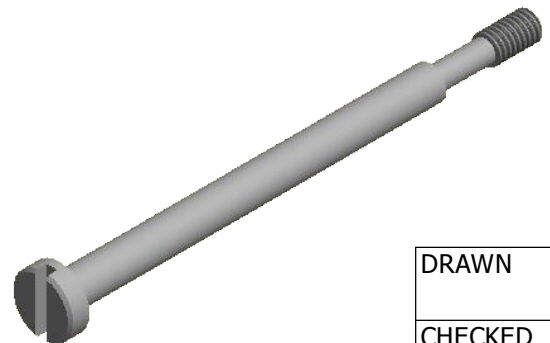

DRAWN	JSD	09-JUL-12
CHECKED	SCN	09-JUL-12
ISSUED		09-JUL-12

**Northern Technologies**

THIS DRAWING IS THE PROPERTY OF NORTHERN TECHNOLOGIES AND SHOULD NOT BE REPRODUCED WITHOUT NORTHERN TECHNOLOGIES WRITTEN PERMISSION.

PART NUMBER		B71E024605M26	
DESCRIPTION M2.6 X 1.80 CMR KIT SCREW Ni			
SIZE	CODE	DWG NO.	REV
A	520_236M26	0002-520-236M26	-

THIS IS A CONTROLLED DOCUMENT AND IS SUBJECT TO CHANGE. CONTACT NORTHERN TECHNOLOGIES ENGINEERING FOR THE LATEST REVISION.

SCALE	N.T.S.	SHEET	1 OF 1
-------	--------	-------	--------

2

1