

REV	DATE	DESCRIPTION	APP
A	25-APR-13	ECN 0718	
B	31-MAR-15	ECN 0767	

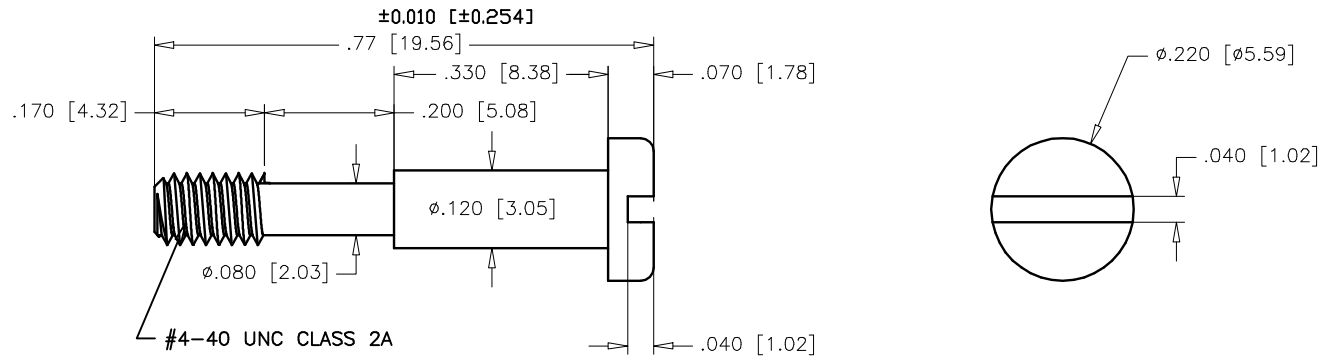

NOTES:

- MATERIAL: 1215 LEAD FREE STEEL OR EQUIV.
- FINISH: BRIGHT NICKEL PER AMS-QQ-N-290 CLASS 1 GRADE F OR EQUIV.
- TOLERANCE: UNLESS OTHERWISE STATED  

DECIMALS	ANGLES
.XX ±0.015 [±0.381]	±2.0°
.XXX ±0.005 [±0.127]	
- ALL DIMENSIONS APPLY AFTER PLATING

UNLESS OTHERWISE SPECIFIED	SIGNATURES	DATE	Northern Technologies		
1. ALL DIMENSIONS ARE IN INCHES [MM] 2. DIMENSIONS ARE TYPICAL	DRAWN Luis C.	01-AUG-05	THIS DRAWING IS THE PROPERTY OF NORTHERN TECHNOLOGIES AND SHOULD NOT BE REPRODUCED WITHOUT NORTHERN TECHNOLOGIES WRITTEN PERMISSION.		
	CHECKED JSD	01-AUG-05			
	ENG		PART NUMBER B71E024602	DESCRIPTION #4-40 X 0.77 CMR KIT SCREW	
	ISSUED	01-AUG-05	SHEET 1	CODE 520_221	DWG NO. 0002-520-221
			SCALE N.T.S.		SHEET 1 OF 1

THIS IS A CONTROLLED DOCUMENT AND IS SUBJECT TO CHANGE. CONTACT NORTHERN TECHNOLOGIES ENGINEERING FOR THE LATEST REVISION.