

REV	DATE	DESCRIPTION	APP
A	13-NOV-08	ECN 0666	
B	25-APR-13	ECN 0718	

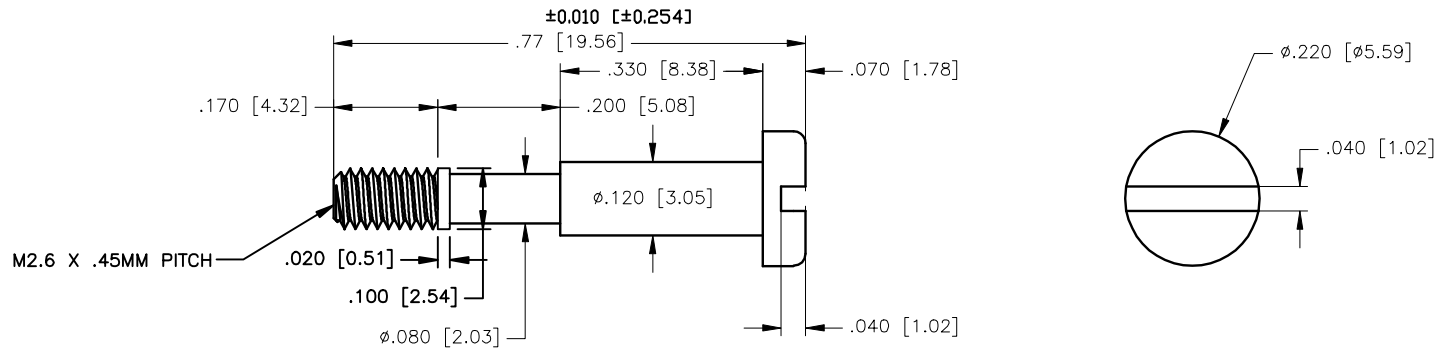

- NOTES:
- MATERIAL: 12L14 FREE-MACHINING STEEL
 - FINISH: BRIGHT NICKEL PER AMS-QQ-N-290 CLASS 1, GRADE F OR EQUIVALENT.
 - TOLERANCE: UNLESS OTHERWISE STATED

DECIMALS	ANGLES
.XX ±0.015 [±0.381]	±2.0°
.XXX ±0.005 [±0.127]	
 - ALL DIMENSIONS APPLY AFTER PLATING

THIS IS A CONTROLLED DOCUMENT AND IS SUBJECT TO CHANGE. CONTACT NORTHERN TECHNOLOGIES ENGINEERING FOR THE LATEST REVISION.

UNLESS OTHERWISE SPECIFIED	SIGNATURES	DATE	Northern Technologies		THIS DRAWING IS THE PROPERTY OF NORTHERN TECHNOLOGIES AND SHOULD NOT BE REPRODUCED WITHOUT NORTHERN TECHNOLOGIES WRITTEN PERMISSION.
1. ALL DIMENSIONS ARE IN INCHES [MM] 2. DIMENSIONS ARE TYPICAL	DRAWN JSD	05-OCT-07	PART NUMBER B71E024602M26		
	CHECKED SCN	05-OCT-07	DESCRIPTION M2.6 X 0.77 CMR KIT SCREW		
	ENG		SHEET 1	CODE 520_221M26	DWG NO. 0002-520-221M26
	ISSUED	10-OCT-07	SCALE N.T.S.		SHEET 1 OF 1