

REVISIONS				
ZONE	REV	DESCRIPTION	DATE	APPROVED
	A	ECN 0731	02-SEP-13	

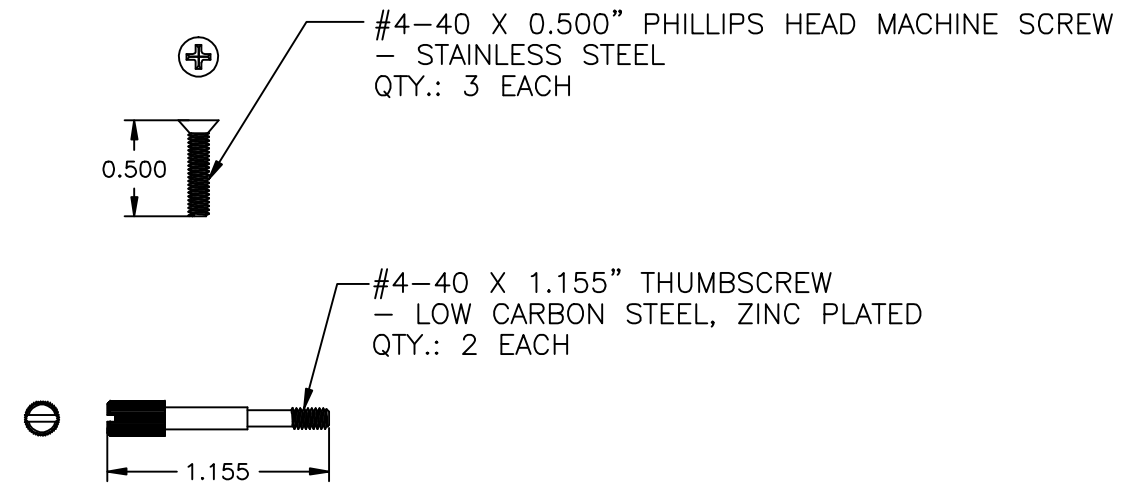
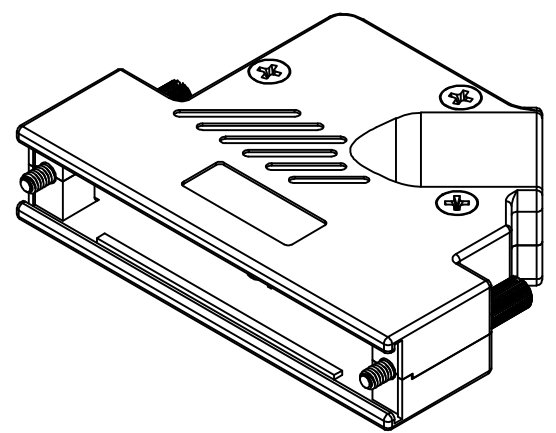
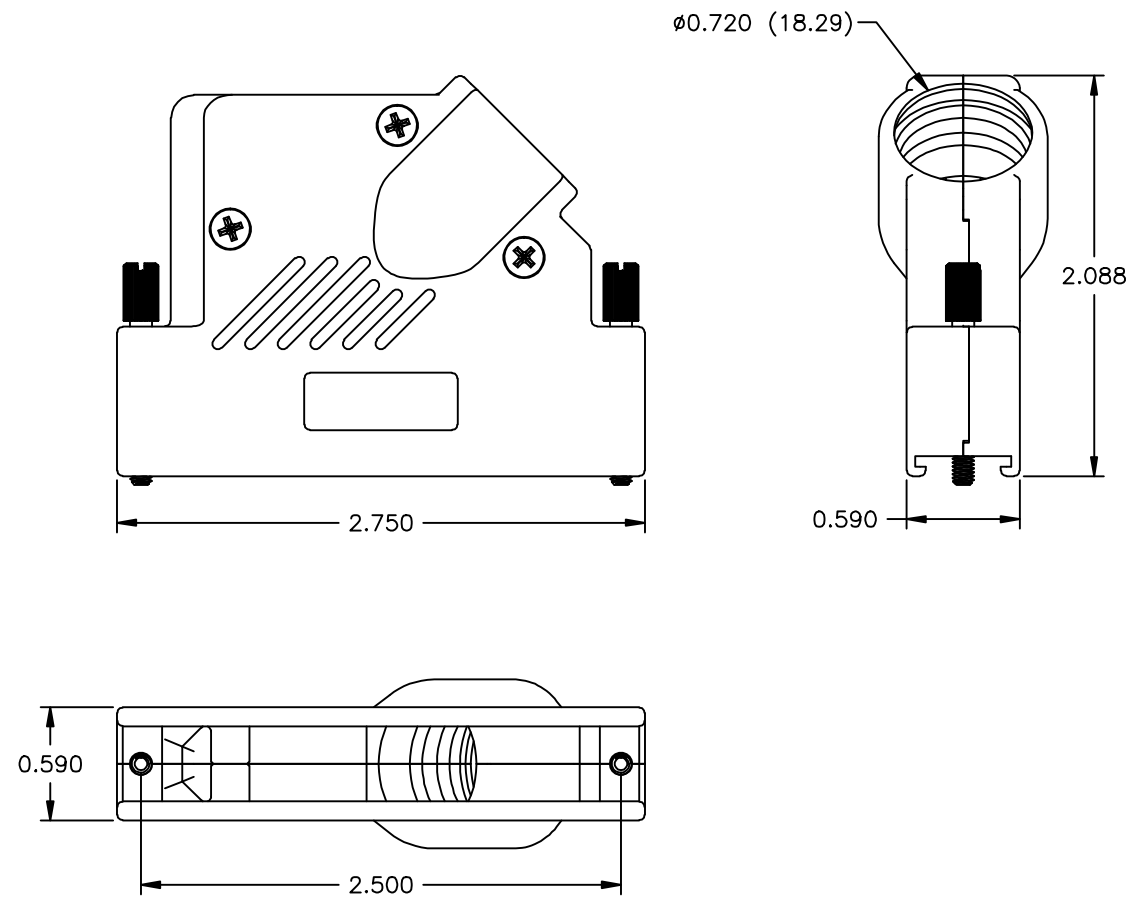

- KIT INCLUDES:
- 1 - COVER TOP (FOR FINISH SEE SHEET 2)
 - 1 - COVER BOTTOM (FOR FINISH SEE SHEET 2)
 - 2 - #4-40 X 1.155 THUMBSCREW
 - 3 - #4-40 PHILLIPS HEAD MACHINE SCREW
 - 1 - COMPRESSION INSERT OR JACKET INSERT
(SEE SHEET 2 FOR CORRESPONDING PART NUMBER)

THIS IS A CONTROLLED DOCUMENT AND IS SUBJECT TO CHANGE. CONTACT NORTHERN TECHNOLOGIES ENGINEERING FOR THE LATEST REVISION.

UNLESS OTHERWISE SPECIFIED		Northern Technologies <small>THIS DRAWING IS THE PROPERTY OF NORTHERN TECHNOLOGIES AND SHOULD NOT BE REPRODUCED WITHOUT NORTHERN TECHNOLOGIES WRITTEN PERMISSION.</small>		
1. ALL DIMENSIONS ARE IN INCHES [MM] 2. DIMENSIONS ARE TYPICAL				
DRAWN Luis C.		PART NUMBER SEE PART NUMBER INFORMATION		
20-APR-10		DESCRIPTION CM 37 45D EXIT w/THUMBSCREWS		
CHECKED JSD	20-APR-10	SIZE B	CODE 200_271	REV
ISSUED	09-SEP-10	DWG NO. 0002-200-271		
		SCALE NTS		SHEET 1 OF 2

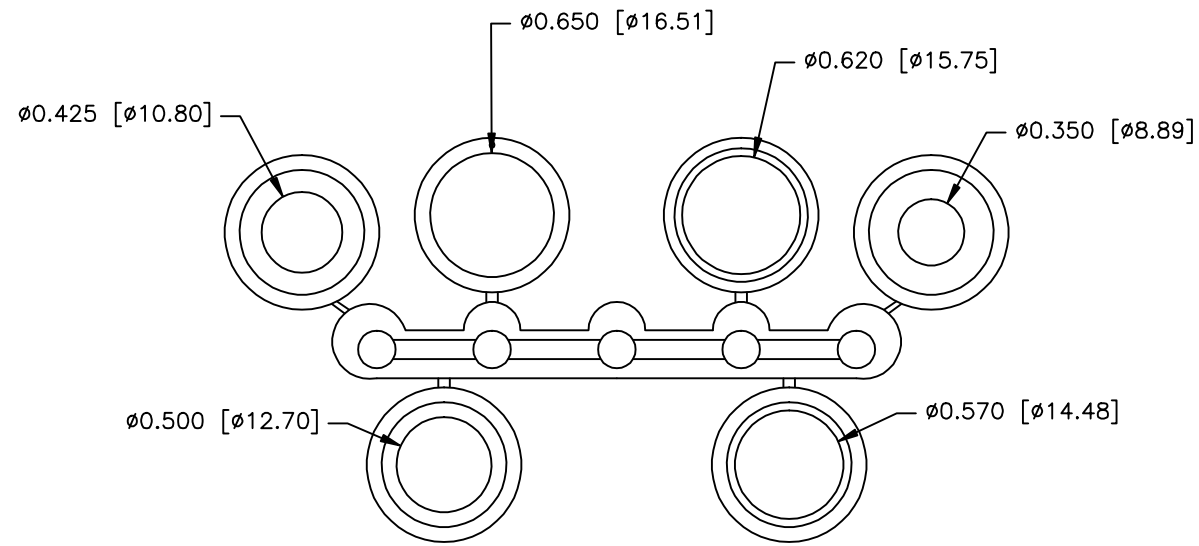

COMPRESSION INSERT TREE
 1.MATERIAL: PVC UL94V-0
 2.COLOR: BLACK
 3.DUROMETER: 80 ±3 TYPE A PER ASTM D2240
 4.DIMENSIONS: INCHES [MM]
 5.TOLERANCE: ±0.020 [0.508]

COMPRESSION INSERT TREE
 QTY. 1

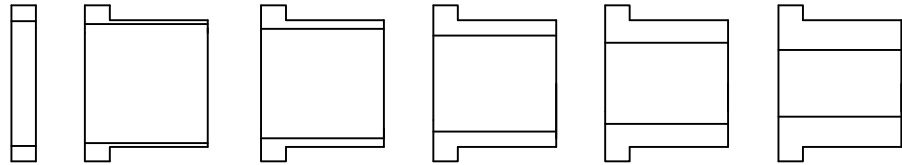

REVISIONS				
ZONE	REV	DESCRIPTION	DATE	APPROVED

NO LOGO

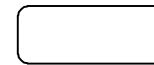

PART NUMBER INFORMATION

PART#	FINISH	STRAIN RELIEF SYSTEM	DESCRIPTION	SUPPLIED
NA95E230000S	NICKEL	JACKET INSERT TREE	NOLOGO TOP	BULK
NA95E230100	NICKEL	JACKET INSERT TREE	BOTTOM	BULK
N95E230000S	NICKEL	JACKET INSERT TREE	NOLOGO	PACKAGED
NA95E230000	NICKEL	COMPRESSION INSERT TREE	NOLOGO TOP	BULK
NA95E230100	NICKEL	COMPRESSION INSERT TREE	BOTTOM	BULK
N95E230000	NICKEL	COMPRESSION INSERT TREE	NOLOGO	PACKAGED
A95E230000	ZINC	COMPRESSION INSERT TREE	NO LOGO TOP	OBSOLETE
A95E230100	ZINC	COMPRESSION INSERT TREE	BOTTOM	OBSOLETE
C95E230000	ZINC	COMPRESSION INSERT TREE	NO LOGO	OBSOLETE
A95E230000S	ZINC	JACKET INSERT TREE	NO LOGO TOP	OBSOLETE
A95E230100	ZINC	JACKET INSERT TREE	BOTTOM	OBSOLETE
C95E230000S	ZINC	JACKET INSERT TREE	NO LOGO	OBSOLETE

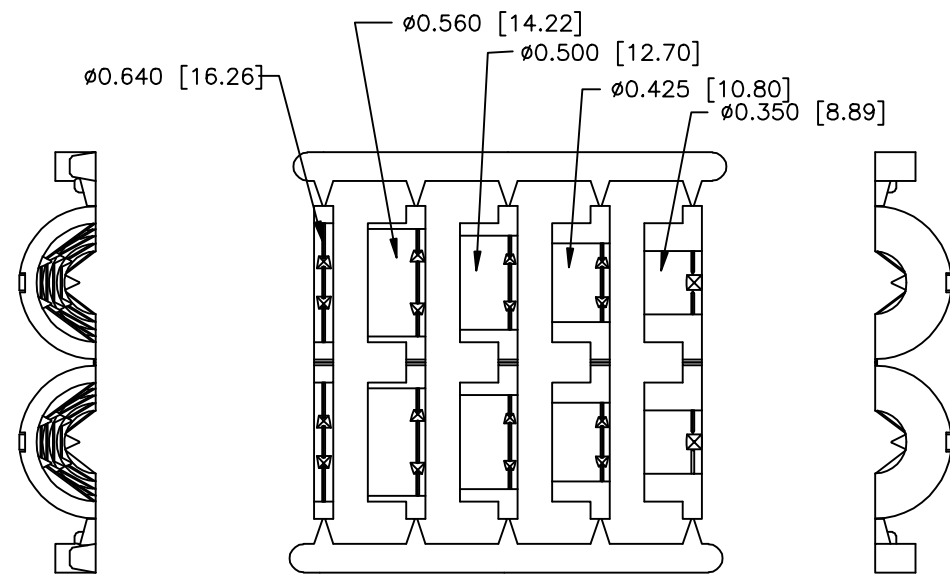

JACKET INSERT TREE
 1.MATERIAL: POLYPROPYLENE UL94HB
 2.COLOR: BLACK
 3.DIMENSIONS: INCHES [MM]
 4.TOLERANCE: ±0.010 [0.254]

JACKET INSERT TREE
 QTY: 1

THIS IS A CONTROLLED DOCUMENT AND IS SUBJECT TO CHANGE. CONTACT NORTHERN TECHNOLOGIES ENGINEERING FOR THE LATEST REVISION.

UNLESS OTHERWISE SPECIFIED 1. ALL DIMENSIONS ARE IN INCHES [MM] 2. DIMENSIONS ARE TYPICAL		Northern Technologies <small>THIS DRAWING IS THE PROPERTY OF NORTHERN TECHNOLOGIES AND SHOULD NOT BE REPRODUCED WITHOUT NORTHERN TECHNOLOGIES WRITTEN PERMISSION.</small>		
DRAWN Luis C.		PART NUMBER SEE PART NUMBER INFORMATION		
20-APR-10		DESCRIPTION CM 37 45D EXIT w/THUMBSCREWS		
CHECKED JSD	20-APR-10	SIZE B	CODE 200_271	DWG NO. 0002-200-271
ISSUED	09-SEP-10	SCALE NTS		REV
				SHEET 2 OF 2