

REVISIONS		
REV	DESCRIPTION	DATE
A	ECN 0657	28-JUL-08
B	ECN 0784	06-JUN-16
C	ECN 0797	17-FEB-17
D	ECN 0853	25-NOV-24
E	NC0001	01/16/2026

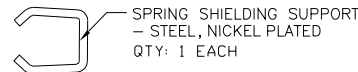
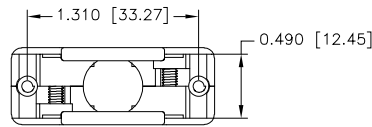
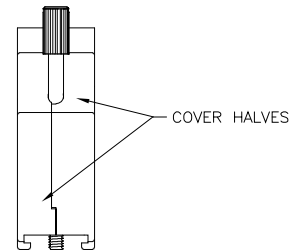
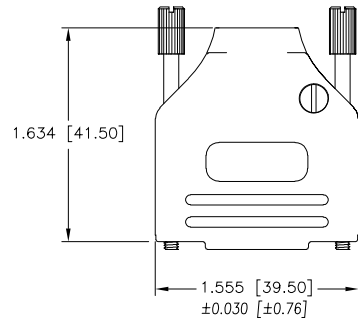

PART NUMBER INFORMATION

PART#	THUMBSCREW OPTION	SUPPLIED
MHDETZK15BKK	MATERIAL - STEEL FINISH - BLACK	PACKAGED
MHDETZK15BPCK	MATERIAL - STEEL FINISH - CLEAR ZINC CAP - PLASTIC - BLACK	PACKAGED

CONNECTOR COVER:

- 1.MATERIAL: ZINC DIE-CAST
- 2.FINISH: BLACK POLYESTER RESIN
- 3.DIMENSIONS: INCHES [MM]
- 4.TOLERANCE: ±0.015 [0.381]

COMPRESSION INSERT TREE

- 1.MATERIAL: ABS
- 2.COLOR: BLACK
- 3.DUROMETER: 70 - TYPE D
- 4.DIMENSIONS: INCHES [MM]
- 5.TOLERANCE: ±0.015 [0.381]

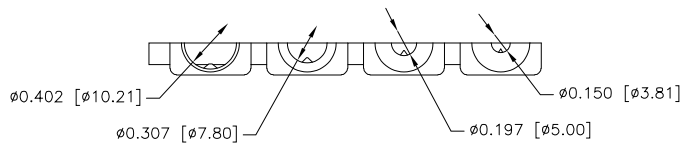
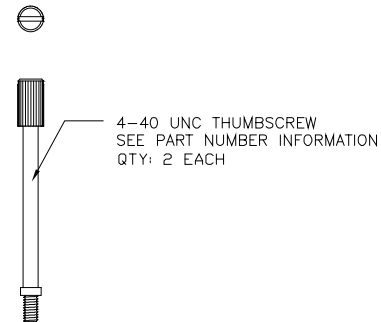
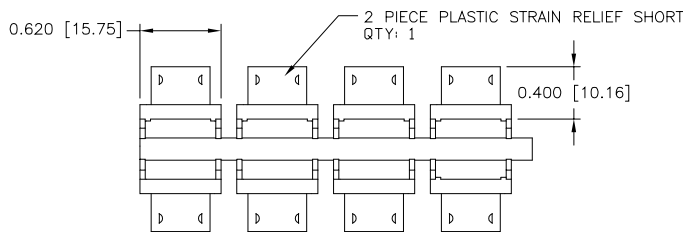

UNLESS OTHERWISE SPECIFIED 1. ALL DIMENSIONS ARE IN INCHES (MM) 2. DIMENSIONS ARE TYPICAL	Northern Technologies			THIS DRAWING IS THE PROPERTY OF NORTHERN TECHNOLOGIES AND SHOULD NOT BE REPRODUCED WITHOUT NORTHERN TECHNOLOGIES WRITTEN PERMISSION.
	PART NUMBER	SEE PART NUMBER INFORMATION		
THIS IS A CONTROLLED DOCUMENT AND IS SUBJECT TO CHANGE. CONTACT NORTHERN TECHNOLOGIES ENGINEERING FOR THE LATEST REVISION.	DESCRIPTION	CMA 15 STRAIGHT EXIT METAL COVER BLACK		
	SIZE B		DWG NO. 0002-200-183	REV E
	SCALE	N.T.S.		SHEET 1 OF 1