

REVISIONS				
ZONE	REV	DESCRIPTION	DATE	APPROVED

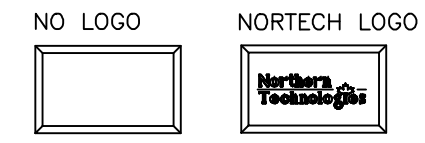

PART NUMBER INFORMATION

PART#	LOGO STYLE	SUPPLIED
N88E000204NT	NO LOGO	PACKAGED
N88E000203NT	NORTECH LOGO	PACKAGED

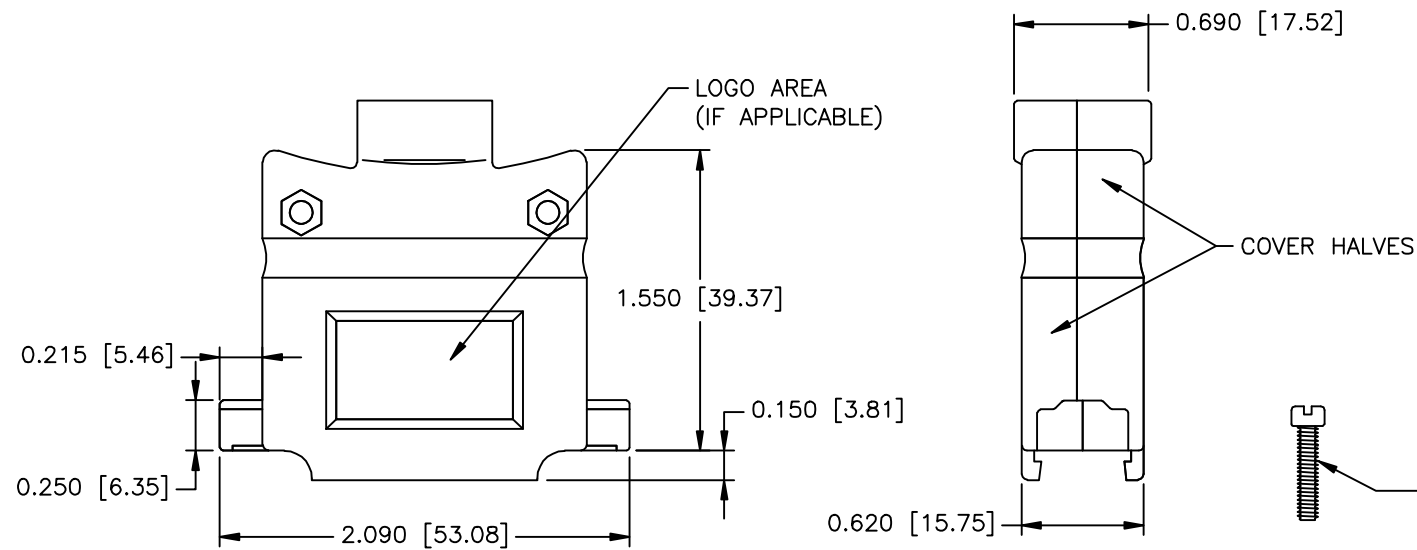
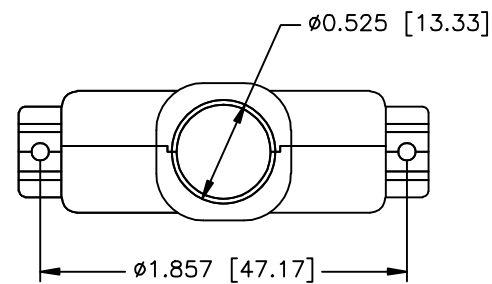
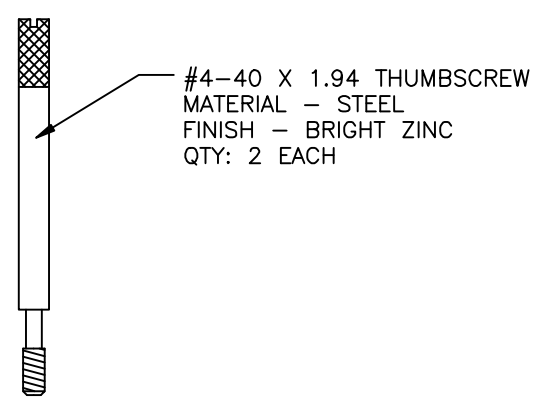
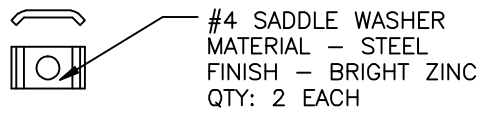
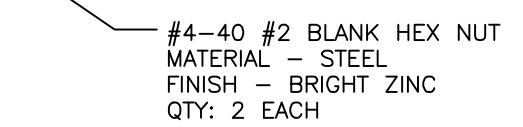
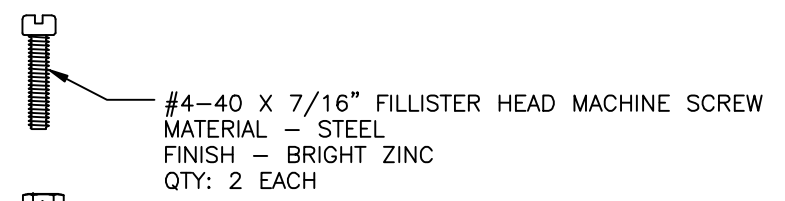
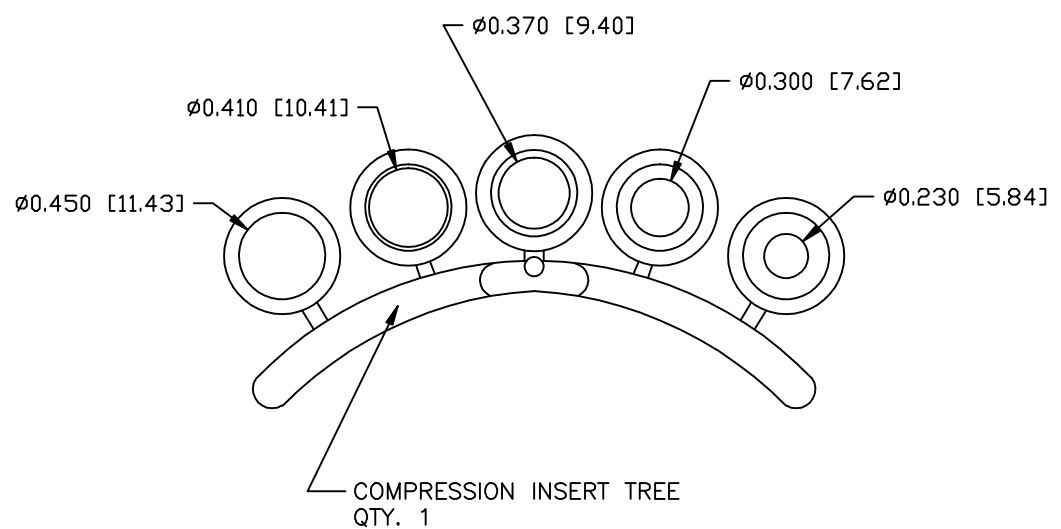

CONNECTOR COVER:

- 1.MATERIAL: ZINC ALLOY
- 2.FINISH: NICKEL PLATING PER NTC SPECIFICATION N/T 000400
- 3.DIMENSIONS: INCHES [MM]
- 4.TOLERANCE: ±0.015 [0.381]

COMPRESSION INSERT TREE

- 1.MATERIAL: THERMOPLASTIC
- 2.COLOR: BLACK
- 3.DUROMETER: 75 ±5 TYPE A PER ASTM D2240
- 4.DIMENSIONS: INCHES [MM]
- 5.TOLERANCE: ±0.020 [0.508]

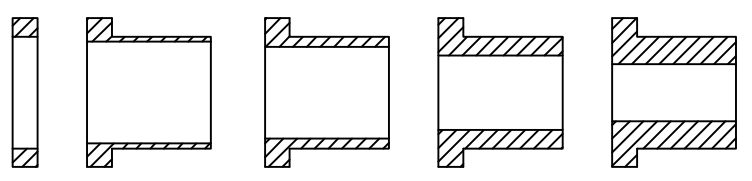

THIS IS A CONTROLLED DOCUMENT AND IS SUBJECT TO CHANGE. CONTACT NORTHERN TECHNOLOGIES ENGINEERING FOR THE LATEST REVISION.

UNLESS OTHERWISE SPECIFIED 1. ALL DIMENSIONS ARE IN INCHES (MM) 2. DIMENSIONS ARE TYPICAL		Northern Technologies <small>THIS DRAWING IS THE PROPERTY OF NORTHERN TECHNOLOGIES AND SHOULD NOT BE REPRODUCED WITHOUT NORTHERN TECHNOLOGIES WRITTEN PERMISSION.</small>		
DRAWN JSD		PART NUMBER SEE PART NUMBER INFORMATION DESCRIPTION CM 25 METAL COVER NICKEL WITH THUMBSCREWS		
CHECKED SCN		SIZE B	CODE 200_103NT	DWG NO. 0002-200-103NT
ISSUED		SCALE 1:1		REV
29-JUL-13		SHEET 1 OF 1		