

REVISIONS				
ZONE	REV	DESCRIPTION	DATE	APPROVED
	A	ECN 0755	12-NOV-14	

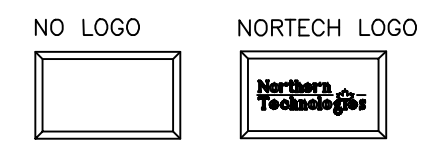

PART NUMBER INFORMATION

PART#	LOGO STYLE	SUPPLIED
N88E000209NT	NO LOGO	PACKAGED
N88E000218NT	NORTECH LOGO	PACKAGED

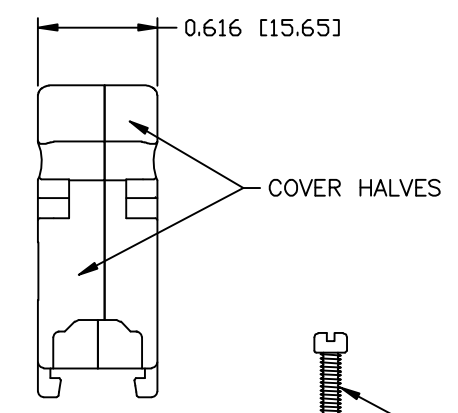
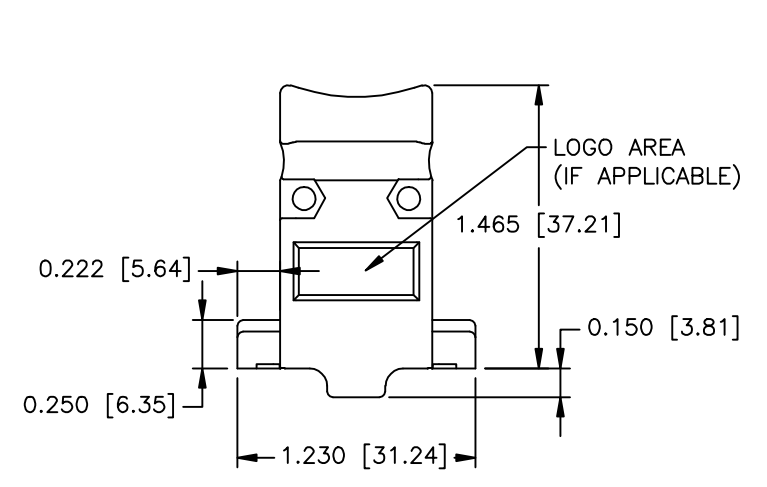
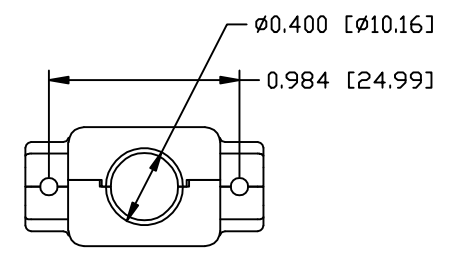
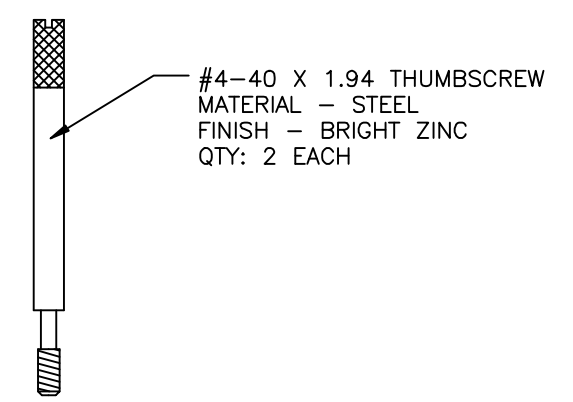
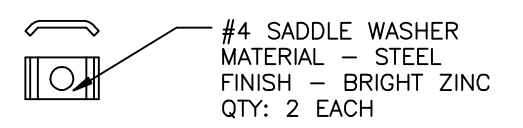
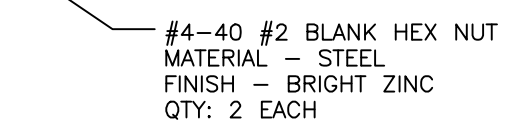
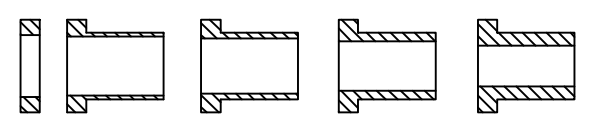
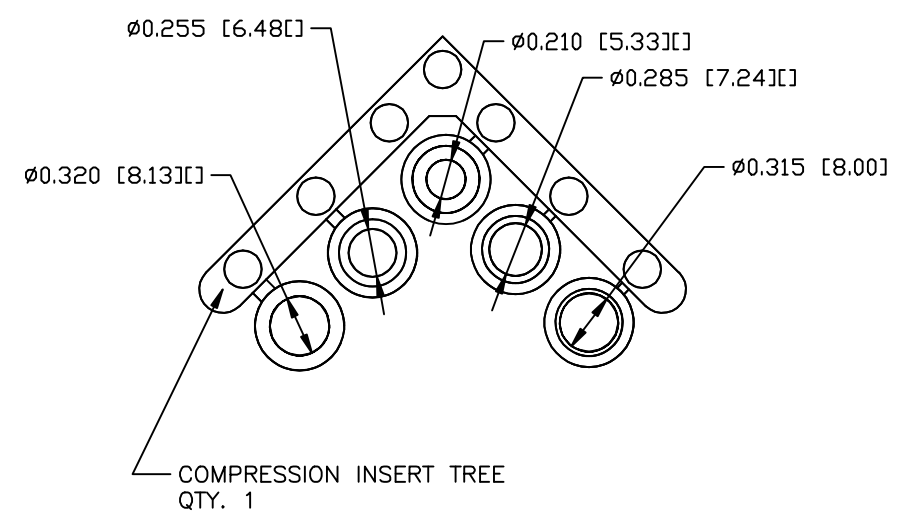

CONNECTOR COVER:

- 1.MATERIAL: ZINC ALLOY
- 2.FINISH: NICKEL PLATING PER NTC SPECIFICATION N/T 000400
- 3.DIMENSIONS: INCHES [MM]
- 4.TOLERANCE: ±0.015 [0.381]

COMPRESSION INSERT TREE

- 1.MATERIAL: THERMOPLASTIC
- 2.COLOR: BLACK
- 3.DUROMETER: 75 ±5 TYPE A PER ASTM D2240
- 4.DIMENSIONS: INCHES [MM]
- 5.TOLERANCE: ±0.020 [0.508]

THIS IS A CONTROLLED DOCUMENT AND IS SUBJECT TO CHANGE. CONTACT NORTHERN TECHNOLOGIES ENGINEERING FOR THE LATEST REVISION.

UNLESS OTHERWISE SPECIFIED 1. ALL DIMENSIONS ARE IN INCHES (MM) 2. DIMENSIONS ARE TYPICAL		Northern Technologies <small>THIS DRAWING IS THE PROPERTY OF NORTHERN TECHNOLOGIES AND SHOULD NOT BE REPRODUCED WITHOUT NORTHERN TECHNOLOGIES WRITTEN PERMISSION.</small>		
DRAWN JSD		PART NUMBER SEE PART NUMBER INFORMATION		
29-JUL-13		DESCRIPTION CM 09 METAL COVER NICKEL WITH THUMBSCREWS		
CHECKED SCN	29-JUL-13	SIZE B	CODE 200_101NT	DWG NO. 0002-200-101NT
ISSUED	29-JUL-13	SCALE 1:1		REV
				SHEET 1 OF 1