

REVISIONS				
ZONE	REV	DESCRIPTION	DATE	APPROVED

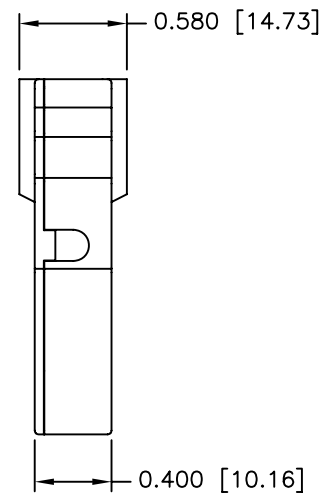
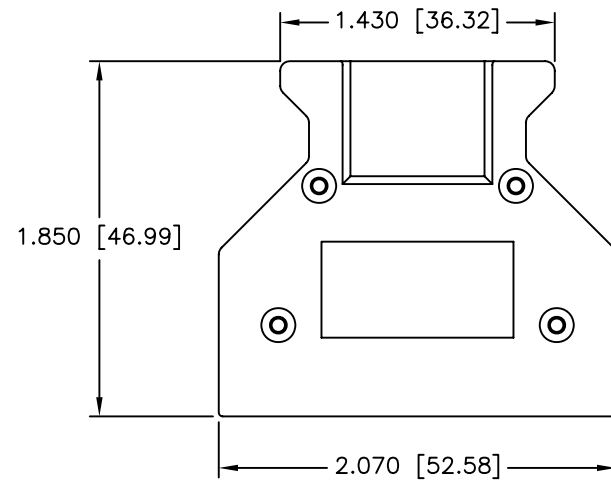
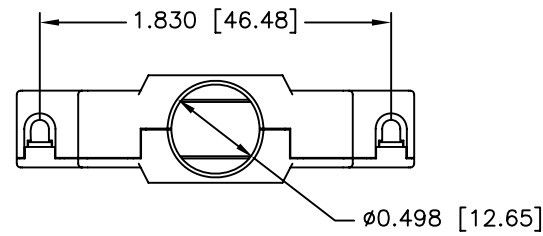

CONNECTOR COVER:

- 1.MATERIAL: ZINC ALLOY
- 2.FINISH: NICKEL PLATING PER NTC SPECIFICATION N/T 000400
- 3.DIMENSIONS: INCHES [MM]
- 4.TOLERANCE: ±0.015 [0.381]

COMPRESSION INSERT TREE

- 1.MATERIAL: THERMOPLASTIC PVC COMPOUND
- 2.COLOR: BLACK
- 3.DUROMETER: 75 ±5 TYPE A PER ASTM D2240
- 4.DIMENSIONS: INCHES [MM]
- 5.TOLERANCE: ±0.020 [0.508]

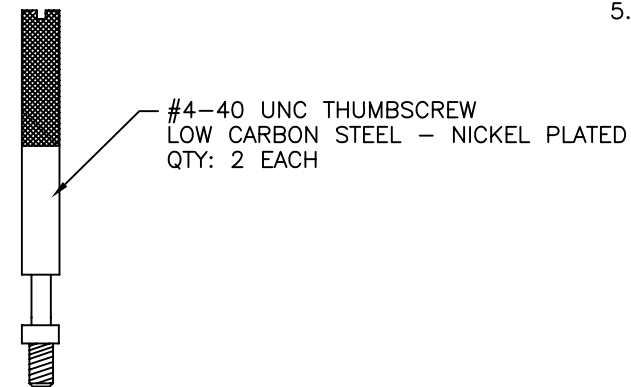
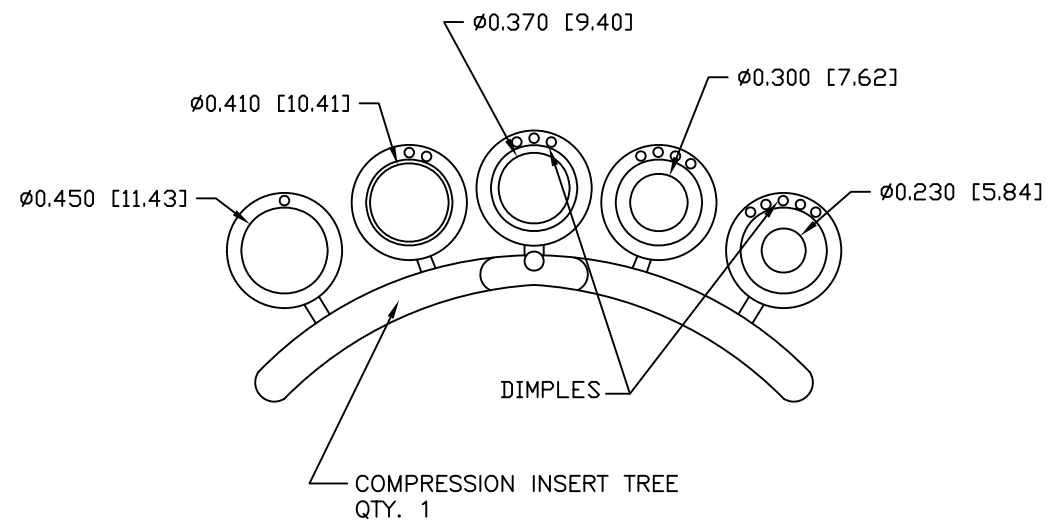

NO LOGO

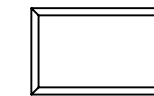

PART NUMBER INFORMATION

PART#	LOGO STYLE	SUPPLIED
NA90E110000T1	NO LOGO TOP COVER	BULK
NA90E110100	BOTTOM COVER	BULK
N90E110000T1	NO LOGO	PACKAGED

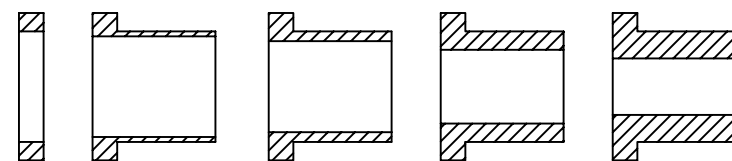
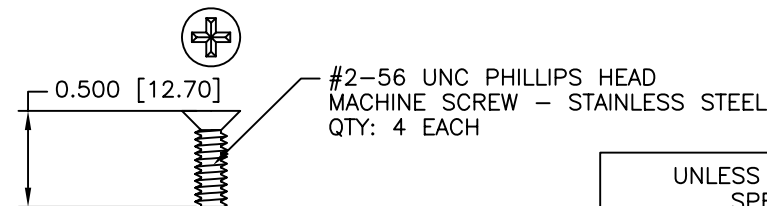

THIS IS A CONTROLLED DOCUMENT AND IS SUBJECT TO CHANGE. CONTACT NORTHERN TECHNOLOGIES ENGINEERING FOR THE LATEST REVISION.

UNLESS OTHERWISE SPECIFIED

1. ALL DIMENSIONS ARE IN INCHES (MM)
2. DIMENSIONS ARE TYPICAL

Northern Technologies

THIS DRAWING IS THE PROPERTY OF NORTHERN TECHNOLOGIES AND SHOULD NOT BE REPRODUCED WITHOUT NORTHERN TECHNOLOGIES WRITTEN PERMISSION.

PART NUMBER SEE PART NUMBER INFORMATION

DESCRIPTION CMHD 50 STR EXIT COVER W/THUMBSCREWS

DRAWN JSD	10-DEC-08	SIZE B	CODE 200_144T1	DWG NO. 0002-200-144T1	REV
CHECKED SCN	10-DEC-08	SCALE N.T.S.	SHEET 1 OF 1		
ISSUED	10-DEC-08				