

REV	DATE	DESCRIPTION	APP
A	22-FEB-12	ECN 0702	

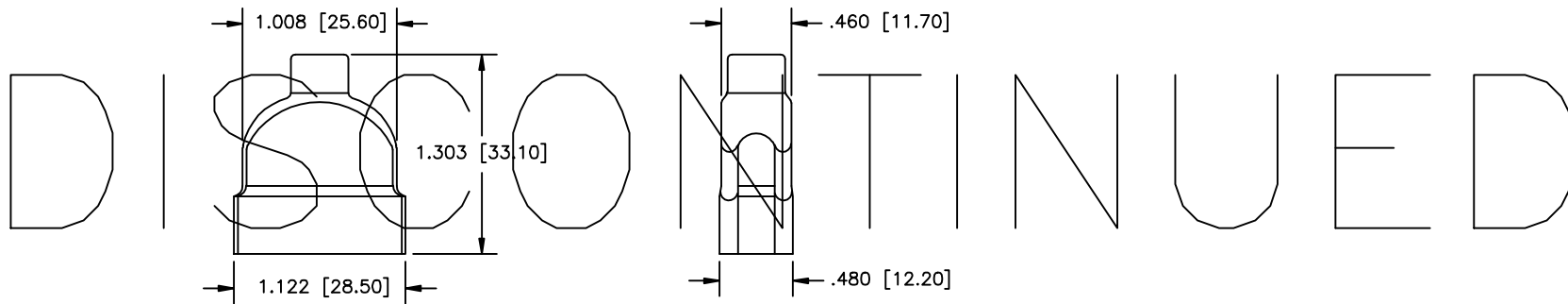
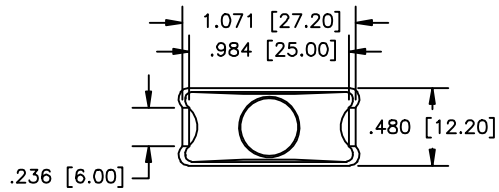

NOTES:
 1. MATERIAL: CR STEEL
 2. FINISH: TIN PLATE

ORDER INFORMATION

PART NUMBER	AØ INCH [MM]
XDVEOMCR055T000	0.217 [5.50]
XDVEOMCR060T000	0.236 [6.00]
XDVEOMCR064T000	0.252 [6.40]
XDVEOMCR075T000	0.295 [7.50]
XDVEOMCR076T000	0.299 [7.60]
XDVEOMCR080T000	0.315 [8.00]
XDVEOMCR084T000	0.330 [8.40]
XDVEOMCR088T000	0.346 [8.80]
XDVEOMCR093T000	0.366 [9.30]

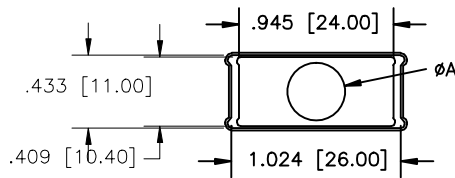

THIS IS A CONTROLLED DOCUMENT AND IS SUBJECT TO CHANGE. CONTACT NORTHERN TECHNOLOGIES ENGINEERING FOR THE LATEST REVISION.

UNLESS OTHERWISE SPECIFIED	SIGNATURES	DATE	Northern Technologies THIS DRAWING IS THE PROPERTY OF NORTHERN TECHNOLOGIES AND SHOULD NOT BE REPRODUCED WITHOUT NORTHERN TECHNOLOGIES WRITTEN PERMISSION.		
1. DIMENSIONS IN INCHES [MM] 2. TOLERANCE UNLESS OTHERWISE SPECIFIED .XXX ± .005 [0.127] .XX ± .02 [0.508] .X ± .03 [0.762] FRACT. ± 1/32 ANGULAR ± 1/2°	DRAWN Luis C.	07-APR-09	PART NUMBER SEE ORDER INFORMATION		
	CHECKED JSD	07-APR-09	DESCRIPTION DVI CAN DISCONTINUED		
	ENG		SHEET 1	CODE 7100_264	DWG NO. 7100-500-264
	ISSUED	02-JUN-09	SCALE N.T.S.	SHEET 1 OF 1	