

REV	DATE	DESCRIPTION	APP
A	19-APR-13	ECN 0720	

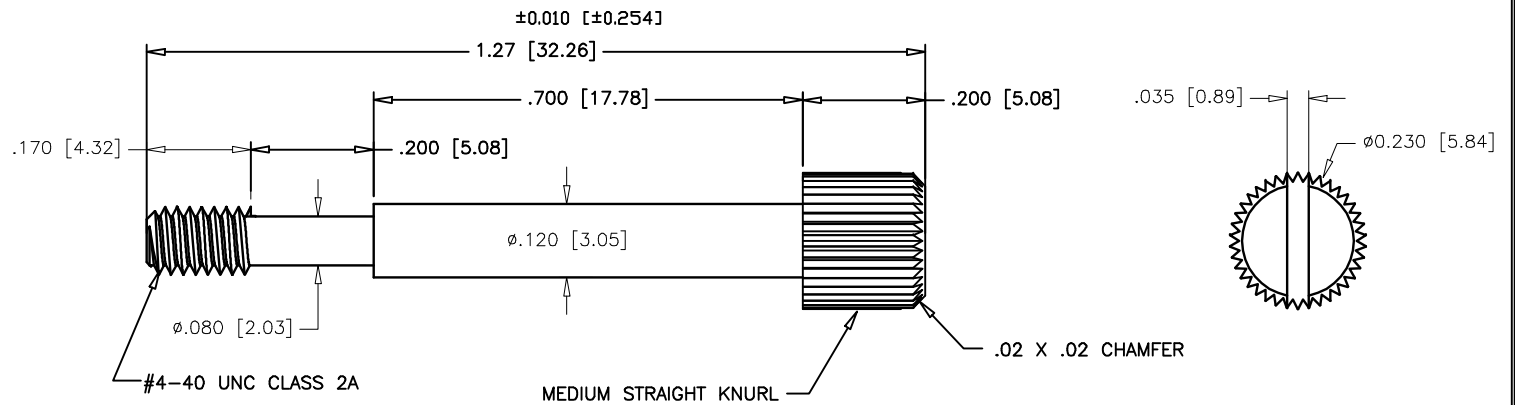

NOTES:

1. MATERIAL: 12L14 FREE-MACHINING STEEL
2. FINISH: BRIGHT NICKEL PER AMS-QQ-N-290 CLASS 1, GRADE F OR EQUIVALENT.
3. TOLERANCE: UNLESS OTHERWISE STATED  

DECIMALS	ANGLES
.XX $\pm 0.015$ [ $\pm 0.381$ ]	$\pm 2.0^\circ$
.XXX $\pm 0.005$ [ $\pm 0.127$ ]	
4. ALL DIMENSIONS APPLY AFTER PLATING

UNLESS OTHERWISE SPECIFIED	SIGNATURES	DATE	Northern Technologies	
1. ALL DIMENSIONS ARE IN INCHES [MM] 2. DIMENSIONS ARE TYPICAL	DRAWN	JSD	13-NOV-07	
	CHECKED	SCN	13-NOV-07	
	ENG			
	ISSUED		19-NOV-07	
			THIS DRAWING IS THE PROPERTY OF NORTHERN TECHNOLOGIES AND SHOULD NOT BE REPRODUCED WITHOUT NORTHERN TECHNOLOGIES WRITTEN PERMISSION.	
			PART NUMBER B71E014303 DESCRIPTION #4-40 X 1.27 THUMBSCREW Ni 990 ULP [RoHS]	
			SHEET 1 SCALE N.T.S.	CODE 520_266 DWG NO. 0002-520-266 SHEET 1 OF 1

THIS IS A CONTROLLED DOCUMENT AND IS SUBJECT TO CHANGE. CONTACT NORTHERN TECHNOLOGIES ENGINEERING FOR THE LATEST REVISION.