

2

1

B

B

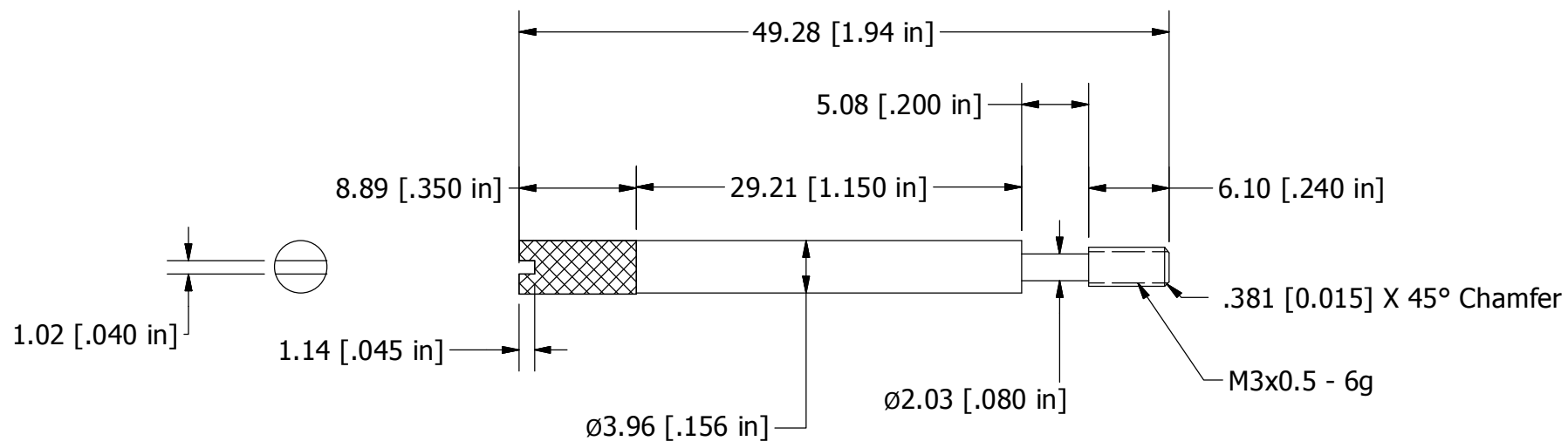

- NOTES:
1. MATERIAL: 1215 LEAD FREE STEEL OR EQUIV.
 2. PLATING: ZINC TRIVALENT CHROMATE
 3. KNURL: DIAMOND MEDIUM KNURL WHERE SHOWN

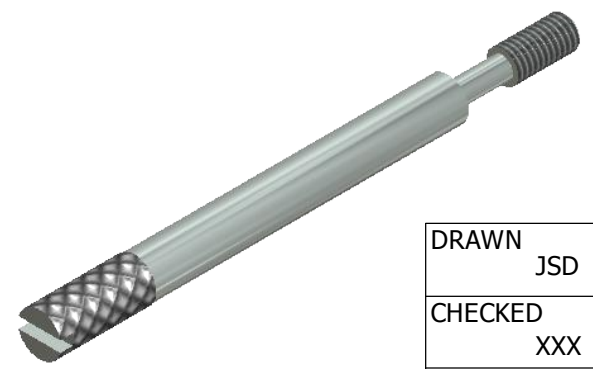

A

A

DRAWN JSD	28-JAN-16	Northern Technologies THIS DRAWING IS THE PROPERTY OF NORTHERN TECHNOLOGIES AND SHOULD NOT BE REPRODUCED WITHOUT NORTHERN TECHNOLOGIES WRITTEN PERMISSION.	
CHECKED XXX	28-JAN-16		
ISSUED	28-JAN-16		
UNLESS OTHERWISE SPECIFIED DIMENSIONS ARE IN MM [INCHES]		PART NUMBER B71E300611M3	
TOLERANCE .XXX ± 1.27 [0.005]		DESCRIPTION M3 X 1.94 THUMBSCREW	
.XX ± 2.54 [0.010]		SIZE A	CODE 520_200M3
.X ± 5.08 [0.020]		DWG NO. 0002-520-200M3	
ANGULAR ± 1½°		SCALE N.T.S.	SHEET 1 OF 1
			REV -

THIS IS A CONTROLLED DOCUMENT AND IS SUBJECT TO CHANGE. CONTACT NORTHERN TECHNOLOGIES ENGINEERING FOR THE LATEST REVISION.

2

1