

REV	DATE	DESCRIPTION	APP
A	14-JUL-05	ECN 0556	
B	20-NOV-14	ECN 0759	

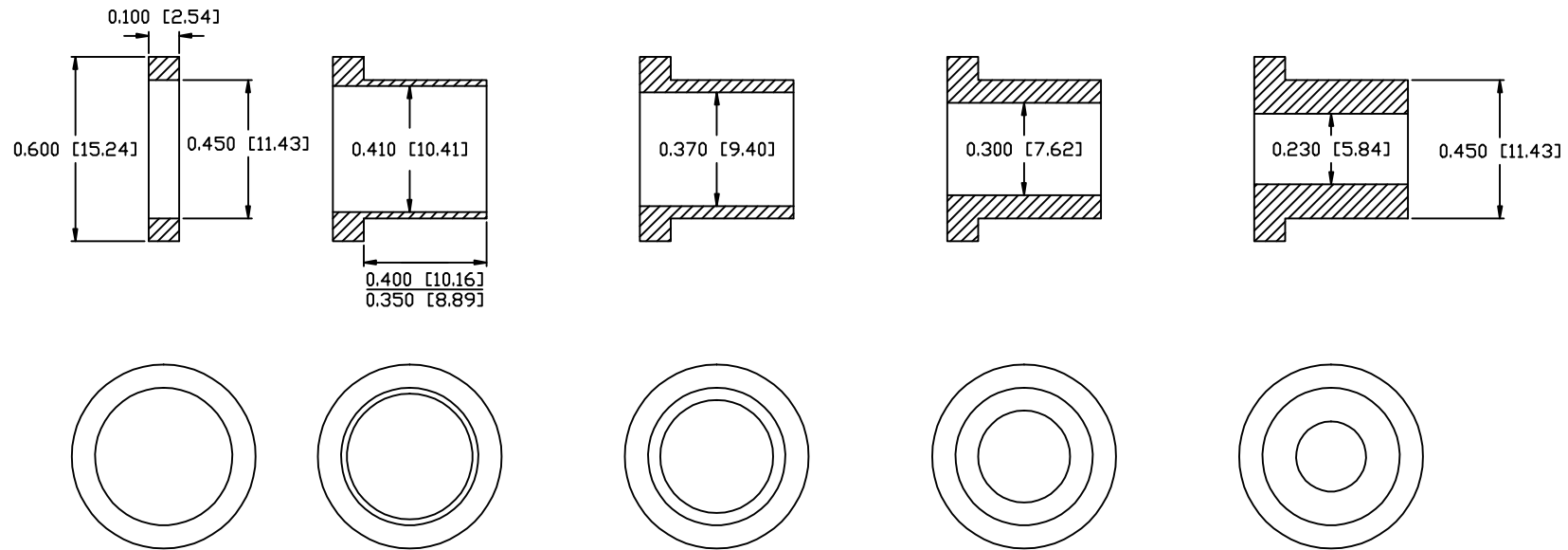

NOTES:

1. ALL DIMENSIONS IN INCHES [MM]
2. MATERIAL - PVC COMPOUND CA6077 BLACK 94V-0
3. DUREMETER: 74 PER ASTM 2240 SHORE A 15 SEC.
4. TOLERANCE: ±0.020 UNLESS OTHERWISE STATED

UNLESS OTHERWISE SPECIFIED	SIGNATURES	DATE	Northern Technologies			THIS DRAWING IS THE PROPERTY OF NORTHERN TECHNOLOGIES AND SHOULD NOT BE REPRODUCED WITHOUT NORTHERN TECHNOLOGIES WRITTEN PERMISSION.
			PART NUMBER A62E000000V			
1. DIMENSIONS IN INCHES [MM] 2. TOLERANCE UNLESS OTHERWISE SPECIFIED .XXX ± .005 [0.127] .XX ± .02 [0.508] .X ± .03 [0.762] FRACT. ± 1/32 ANGULAR ± 1/2°	DRAWN	JSD	07-JUN-05	DESCRIPTION COMPRESSION INSERT 25C 94V-0		
	CHECKED	SCN	07-JUN-05	SHEET	CODE	DWG NO.
	ENG			1	520_006V0	0002-520-006V0
	ISSUED		07-JUN-05	SCALE	N.T.S.	SHEET 1 OF 1

THIS IS A CONTROLLED DOCUMENT AND IS SUBJECT TO CHANGE. CONTACT NORTHERN TECHNOLOGIES ENGINEERING FOR THE LATEST REVISION.