

REV	DATE	DESCRIPTION	APP
A	18-FEB-97	ECN 0122	
B	11-JAN-02	ECN 0300	
C	20-FEB-02	ECN 0308	

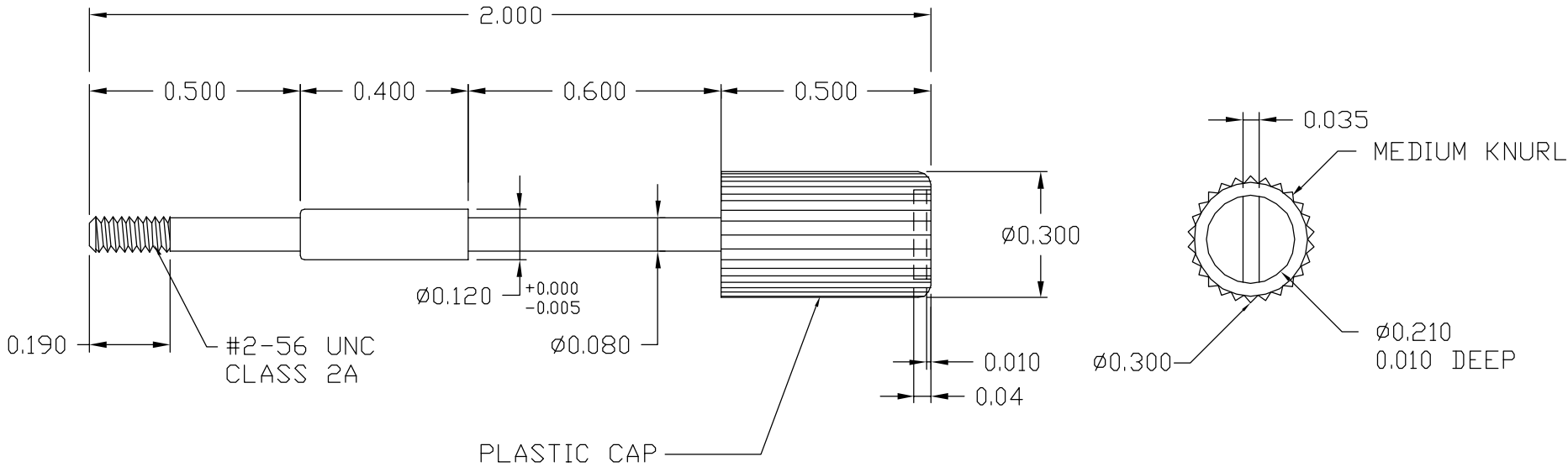

- NOTES:
1. MATERIAL: LOW CARBON STEEL
  2. FINISH: BLACK ZINC
  3. KNOB: POLYPROPYLENE - BLACK

UNLESS OTHERWISE SPECIFIED		SIGNATURES	DATE	Northern Technologies		
1. ALL DIMENSIONS ARE IN INCHES (MM) 2. DIMENSIONS ARE TYPICAL	DRAWN	Luis C.	17-JUL-96	PART NUMBER B71014305		
	CHECKED	JSD	17-JUL-96	DESCRIPTION #2-56 50/68C BOOT T/SCREW W/BLACK KNOB		
	ENG					
	ISSUED		17-JUL-96	SHEET 1	CODE 420_118	DWG NO. 0002-420-118
			SCALE N.T.S.	SHEET 1 OF 1		

THIS DRAWING IS THE PROPERTY OF NORTHERN TECHNOLOGIES AND SHOULD NOT BE REPRODUCED WITHOUT NORTHERN TECHNOLOGIES' WRITTEN PERMISSION.