

REVISIONS				
ZONE	REV	DESCRIPTION	DATE	APPROVED
	A	ECN 0731	02-SEP-13	

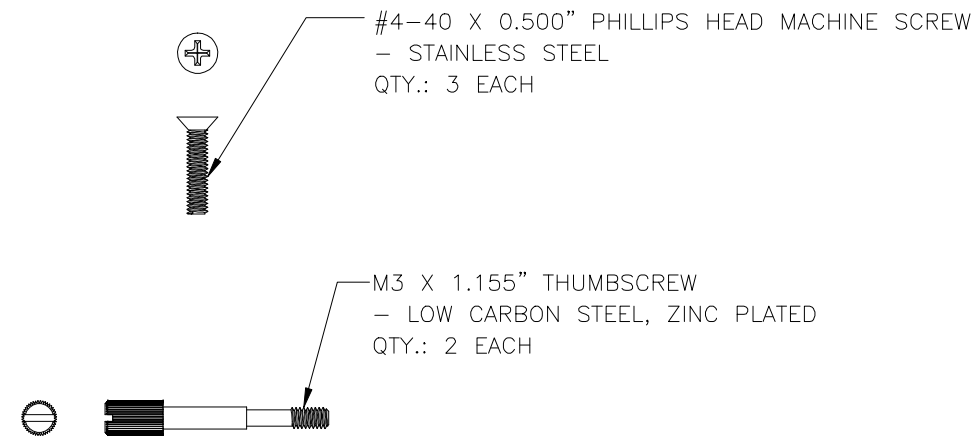
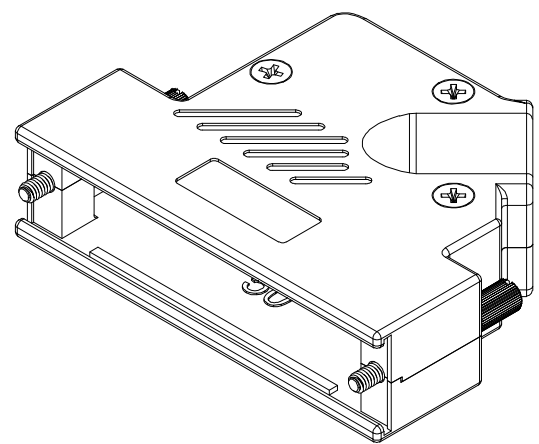
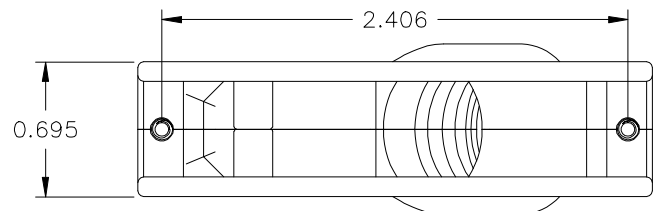
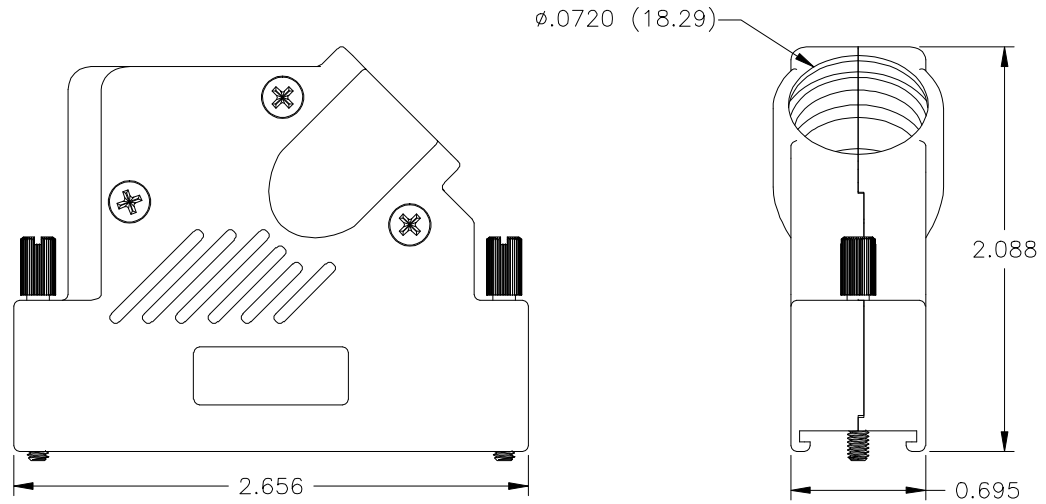

- KIT INCLUDES:
- 1 - COVER TOP (FOR FINISH SEE SHEET 2)
  - 1 - COVER BOTTOM (FOR FINISH SEE SHEET 2)
  - 2 - M3 X 1.155 THUMBSCREW
  - 3 - #4-40 PHILLIPS HEAD MACHINE SCREW
  - 1 - COMPRESSION INSERT OR JACKET INSERT (SEE SHEET 2 FOR CORRESPONDING PART NUMBER)

THIS IS A CONTROLLED DOCUMENT AND IS SUBJECT TO CHANGE. CONTACT NORTHERN TECHNOLOGIES ENGINEERING FOR THE LATEST REVISION.

UNLESS OTHERWISE SPECIFIED		<b>Northern Technologies</b> <small>THIS DRAWING IS THE PROPERTY OF NORTHERN TECHNOLOGIES AND SHOULD NOT BE REPRODUCED WITHOUT NORTHERN TECHNOLOGIES' WRITTEN PERMISSION.</small>		
1. ALL DIMENSIONS ARE IN INCHES [MM] 2. DIMENSIONS ARE TYPICAL				
DRAWN		PART NUMBER SEE PART NUMBER INFORMATION		
Luis C. 25-FEB-11		DESCRIPTION CM 50 45D EXIT w/ M3 THUMBSCREWS		
CHECKED	JSD 25-FEB-11	SIZE	CODE	DWG NO.
ISSUED	25-FEB-11	B	200_272M3	0002-200-272M3
		SCALE	NTS	SHEET 1 OF 2
				REV

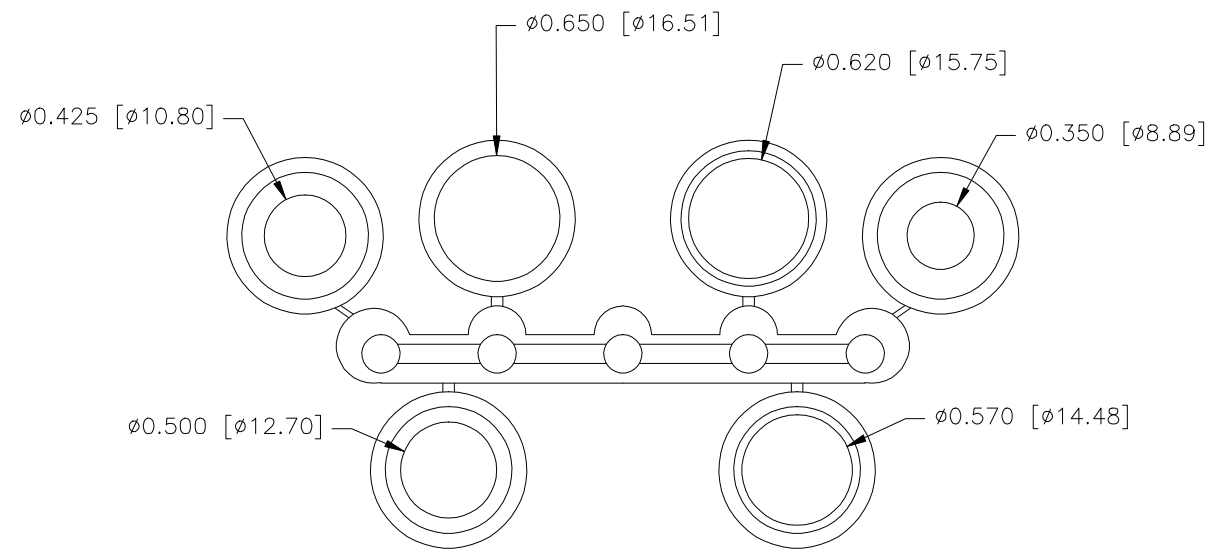

COMPRESSION INSERT TREE  
 1.MATERIAL: PVC UL94V-0  
 2.COLOR: BLACK  
 3.DUROMETER: 80  $\pm$ 3 TYPE A PER ASTM D2240  
 4.DIMENSIONS: INCHES [MM]  
 5.TOLERANCE:  $\pm$ 0.020 [0.508]

COMPRESSION INSERT TREE  
 QTY. 1

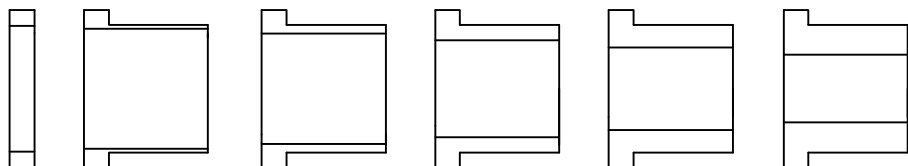

NO LOGO



PART NUMBER INFORMATION

PART#	FINISH	STRAIN RELIEF SYSTEM	DESCRIPTION	SUPPLIED
NA95E240000SM3	NICKEL	JACKET INSERT TREE	NOLOGO TOP	BULK
NA95E240100	NICKEL	JACKET INSERT TREE	BOTTOM	BULK
N95E240000SM3	NICKEL	JACKET INSERT TREE	NOLOGO	PACKAGED
NA95E240000M3	NICKEL	COMPRESSION INSERT TREE	NOLOGO TOP	BULK
NA95E240100	NICKEL	COMPRESSION INSERT TREE	BOTTOM	BULK
N95E240000M3	NICKEL	COMPRESSION INSERT TREE	NOLOGO	PACKAGED
A95E240000M3	ZINC	COMPRESSION INSERT TREE	NO LOGO TOP	OBSOLETE
A95E240100	ZINC	COMPRESSION INSERT TREE	BOTTOM	OBSOLETE
C95E240000M3	ZINC	COMPRESSION INSERT TREE	NO LOGO	OBSOLETE
A95E240000SM3	ZINC	JACKET INSERT TREE	NO LOGO TOP	OBSOLETE
A95E240100	ZINC	JACKET INSERT TREE	BOTTOM	OBSOLETE
C95E240000SM3	ZINC	JACKET INSERT TREE	NO LOGO	OBSOLETE

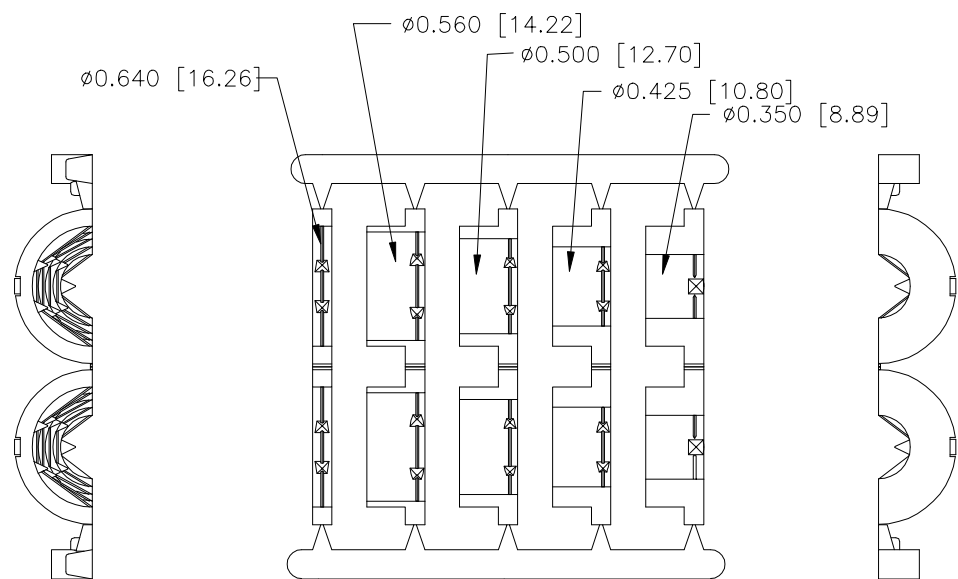

JACKET INSERT TREE  
 1.MATERIAL: POLYPROPYLENE UL94HB  
 2.COLOR: BLACK  
 3.DIMENSIONS: INCHES [MM]  
 4.TOLERANCE:  $\pm$ 0.010 [0.254]

JACKET INSERT TREE  
 QTY: 1

THIS IS A CONTROLLED DOCUMENT AND IS SUBJECT TO CHANGE. CONTACT NORTHERN TECHNOLOGIES ENGINEERING FOR THE LATEST REVISION.

REVISIONS				
ZONE	REV	DESCRIPTION	DATE	APPROVED

UNLESS OTHERWISE SPECIFIED 1. ALL DIMENSIONS ARE IN INCHES [MM] 2. DIMENSIONS ARE TYPICAL		<b>Northern Technologies</b> <small>THIS DRAWING IS THE PROPERTY OF NORTHERN TECHNOLOGIES AND SHOULD NOT BE REPRODUCED WITHOUT NORTHERN TECHNOLOGIES' WRITTEN PERMISSION.</small>		
DRAWN Luis C.		PART NUMBER SEE PART NUMBER INFORMATION		
25-FEB-11		DESCRIPTION CM 50 45D EXIT w/ M3 THUMBSCREWS		
CHECKED JSD	25-FEB-11	SIZE B	CODE 200_272M3	DWG NO. 0002-200-272M3
ISSUED	25-FEB-11	SCALE NTS	REV	
SHEET 2 OF 2				