

 #4-40 X 0.500" PHILLIPS HEAD MACHINE SCREW  
 - STAINLESS STEEL  
 QTY.: 2 EACH

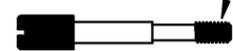

 #4-40 X 1.155" THUMBSCREW  
 - LOW CARBON STEEL, ZINC PLATED  
 QTY.: 2 EACH



REVISIONS				
ZONE	REV	DESCRIPTION	DATE	APPROVED
	A	ECN 0731	02-SEP-13	

- KIT INCLUDES:
- 1 - COVER TOP (FOR FINISH SEE SHEET 2)
  - 1 - COVER BOTTOM (FOR FINISH SEE SHEET 2)
  - 2 - #4-40 X 1.155 THUMBSCREW
  - 2 - #4-40 PHILLIPS HEAD MACHINE SCREW
  - 1 - COMPRESSION INSERT OR JACKET INSERT  
(SEE SHEET 2 FOR CORRESPONDING PART NUMBER)

THIS IS A CONTROLLED DOCUMENT AND IS SUBJECT TO CHANGE. CONTACT NORTHERN TECHNOLOGIES ENGINEERING FOR THE LATEST REVISION.

UNLESS OTHERWISE SPECIFIED		<b>Northern Technologies</b> <small>THIS DRAWING IS THE PROPERTY OF NORTHERN TECHNOLOGIES AND SHOULD NOT BE REPRODUCED WITHOUT NORTHERN TECHNOLOGIES WRITTEN PERMISSION.</small>		
1. ALL DIMENSIONS ARE IN INCHES [MM] 2. DIMENSIONS ARE TYPICAL				
DRAWN Luis C. 22-APR-10		PART NUMBER SEE PART NUMBER INFORMATION		
CHECKED JSD 22-APR-10		DESCRIPTION CM 25 45D EXIT w/THUMBSCREWS		
ISSUED	22-APR-10	SIZE B	CODE 200_270	DWG NO. 0002-200-270
		SCALE NTS		SHEET 1 OF 2

REVISIONS				
ZONE	REV	DESCRIPTION	DATE	APPROVED

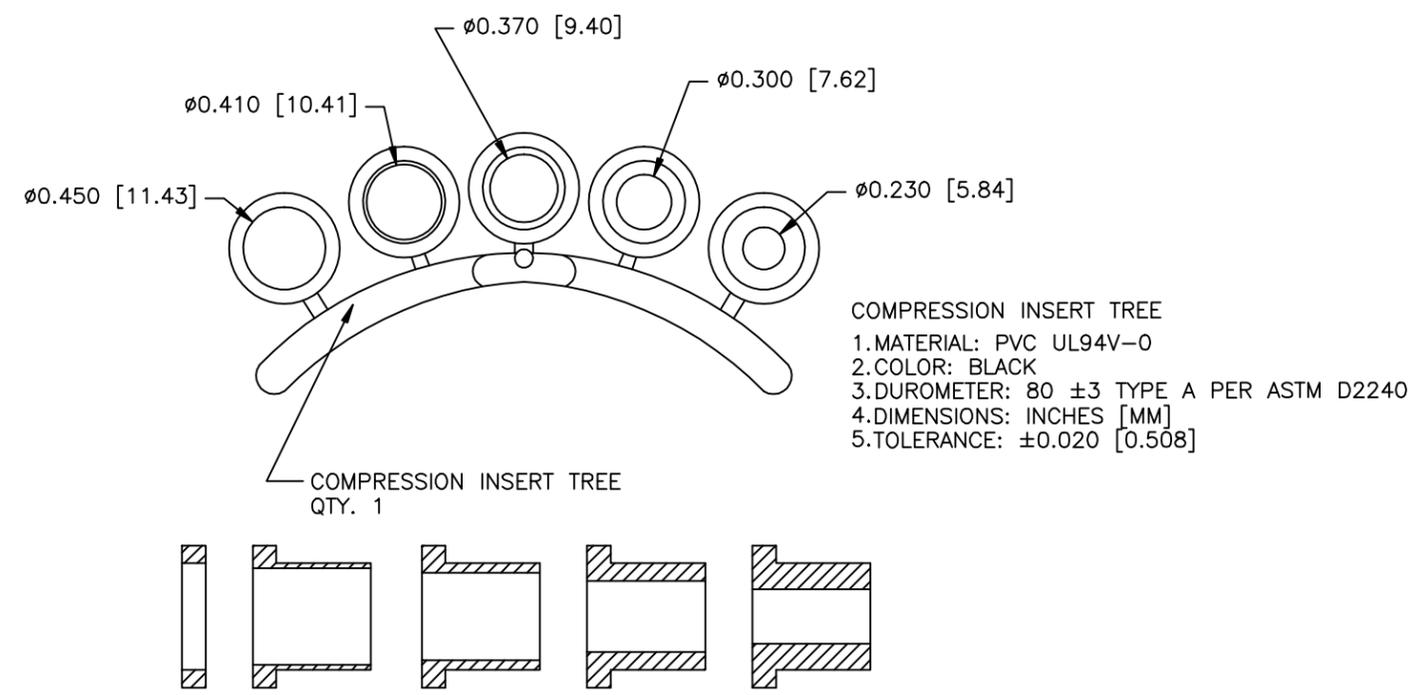

NO LOGO

PART NUMBER INFORMATION

PART#	FINISH	STRAIN RELIEF SYSTEM	DESCRIPTION	SUPPLIED
NA95E220000S	NICKEL	JACKET INSERT TREE	NOLOGO TOP	BULK
NA95E220100	NICKEL	JACKET INSERT TREE	BOTTOM	BULK
N95E220000S	NICKEL	JACKET INSERT TREE	NOLOGO	PACKAGED
NA95E220000	NICKEL	COMPRESSION INSERT TREE	NOLOGO TOP	BULK
NA95E220100	NICKEL	COMPRESSION INSERT TREE	BOTTOM	BULK
N95E220000	NICKEL	COMPRESSION INSERT TREE	NOLOGO	PACKAGED
A95E220000	ZINC	COMPRESSION INSERT TREE	NO LOGO TOP	OBSOLETE
A95E220100	ZINC	COMPRESSION INSERT TREE	BOTTOM	OBSOLETE
C95E220000	ZINC	COMPRESSION INSERT TREE	NO LOGO	OBSOLETE
A95E220000S	ZINC	JACKET INSERT TREE	NO LOGO TOP	OBSOLETE
A95E220100	ZINC	JACKET INSERT TREE	BOTTOM	OBSOLETE
C95E220000S	ZINC	JACKET INSERT TREE	NO LOGO	OBSOLETE

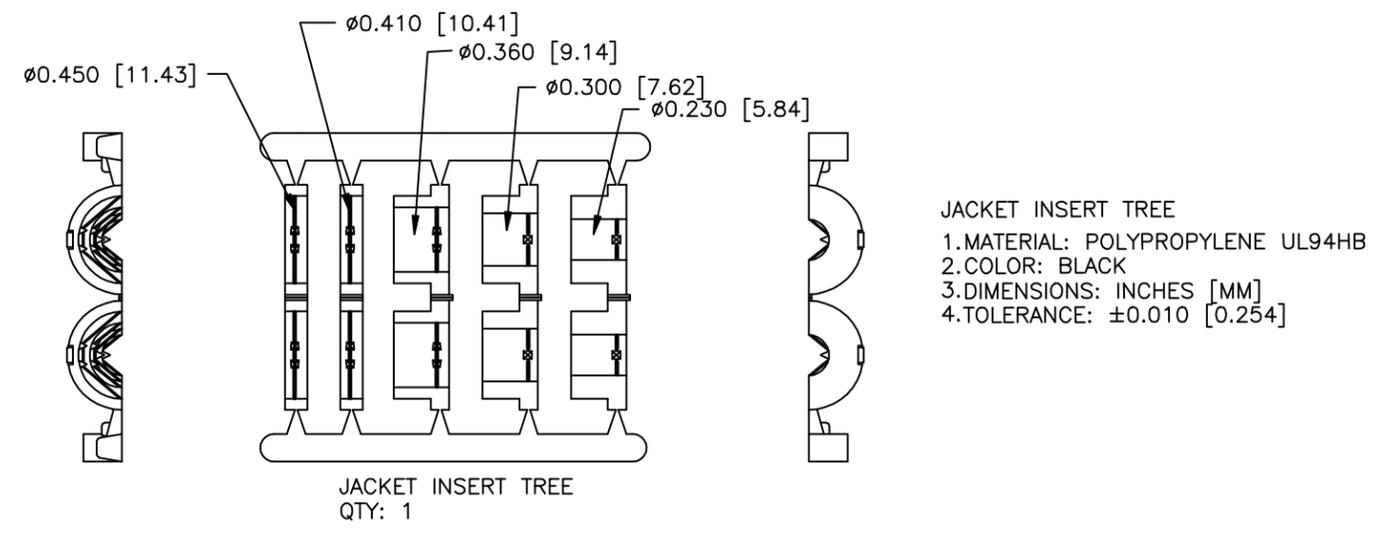

THIS IS A CONTROLLED DOCUMENT AND IS SUBJECT TO CHANGE. CONTACT NORTHERN TECHNOLOGIES ENGINEERING FOR THE LATEST REVISION.

UNLESS OTHERWISE SPECIFIED		<b>Northern Technologies</b> <small>THIS DRAWING IS THE PROPERTY OF NORTHERN TECHNOLOGIES AND SHOULD NOT BE REPRODUCED WITHOUT NORTHERN TECHNOLOGIES' WRITTEN PERMISSION.</small>		
1. ALL DIMENSIONS ARE IN INCHES [MM] 2. DIMENSIONS ARE TYPICAL				
DRAWN Luis C. 22-APR-10		PART NUMBER SEE PART NUMBER INFORMATION DESCRIPTION CM 25 45D EXIT w/THUMBSCREWS		
CHECKED JSD 22-APR-10	SIZE B CODE 200_270	DWG NO. 0002-200-270		REV
ISSUED 22-APR-10	SCALE NTS	SHEET 2 OF 2		