

REVISIONS				
ZONE	REV	DESCRIPTION	DATE	APPROVED
	A	ECN 0731	02-SEP-13	
	B	ECN 0755	12-NOV-14	
	C	ECN 0836	24-MAY-22	

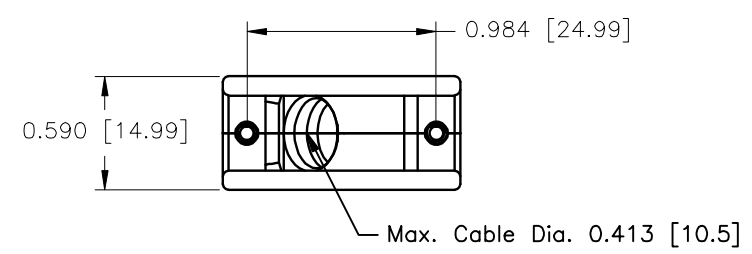

CONNECTOR COVER:
 1.MATERIAL: ZINC ALLOY
 2.FINISH: SEE ORDER INFORMATION (SHEET 2)
 3.DIMENSIONS: INCHES [MM]
 4.TOLERANCE: ±0.015 [0.381]

KIT INCLUDES:
 1 - COVER TOP (FOR FINISH SEE SHEET 2)
 1 - COVER BOTTOM (FOR FINISH SEE SHEET 2)
 1 - M3 X 1.085 THUMBSCREW
 1 - M3 X 1.155 THUMBSCREW
 2 - #4-40 PHILLIPS HEAD MACHINE SCREW
 1 - COMPRESSION INSERT OR JACKET INSERT
 (SEE SHEET 2 FOR CORRESPONDING PART NUMBER)

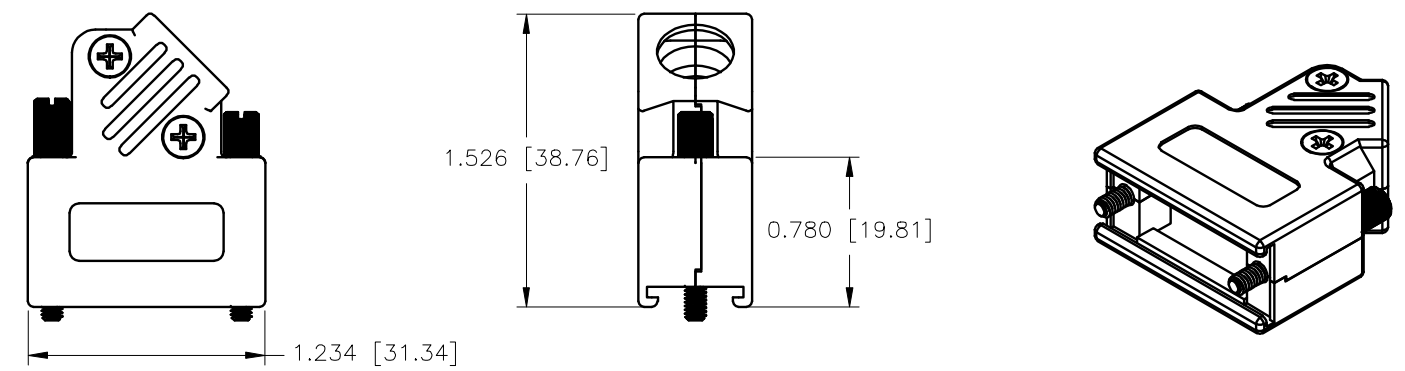
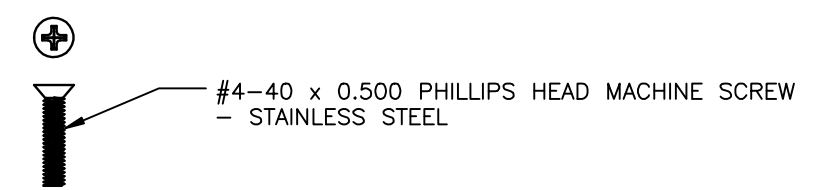
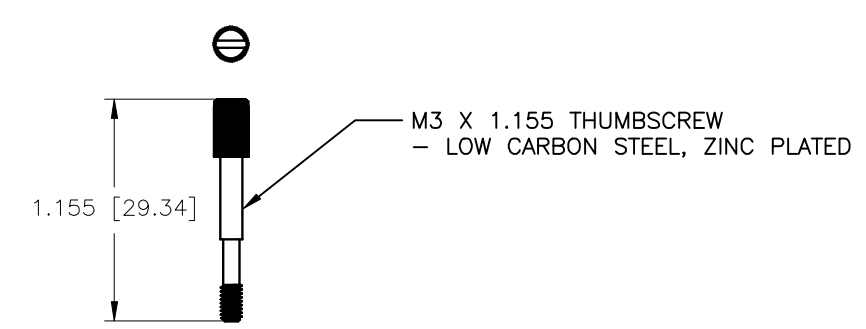
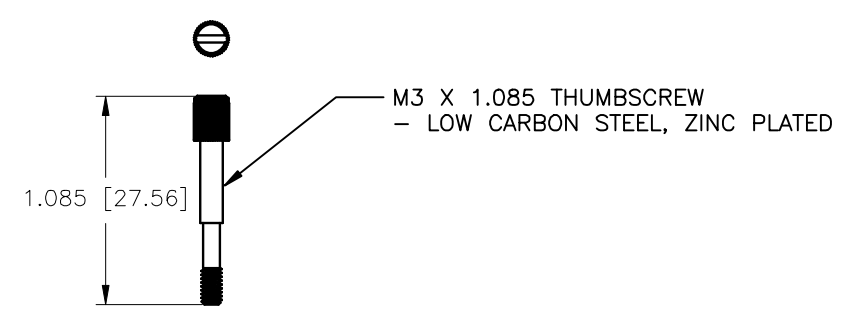

THIS IS A CONTROLLED DOCUMENT AND IS SUBJECT TO CHANGE. CONTACT NORTHERN TECHNOLOGIES ENGINEERING FOR THE LATEST REVISION.

UNLESS OTHERWISE SPECIFIED 1. ALL DIMENSIONS ARE IN INCHES [MM] 2. DIMENSIONS ARE TYPICAL		Northern Technologies <small>THIS DRAWING IS THE PROPERTY OF NORTHERN TECHNOLOGIES AND SHOULD NOT BE REPRODUCED WITHOUT NORTHERN TECHNOLOGIES WRITTEN PERMISSION.</small>		
DRAWN Luis C. 25-FEB-11		PART NUMBER SEE ORDER INFORMATION		
CHECKED JSD 25-FEB-11		DESCRIPTION CM 09 45D EXIT w/ M3 THUMBSCREWS		
ISSUED 25-FEB-11		SIZE B	CODE 200_239M3	DWG NO. 0002-200-239M3
		SCALE NTS		REV SHEET 1 OF 2

REVISIONS				
ZONE	REV	DESCRIPTION	DATE	APPROVED

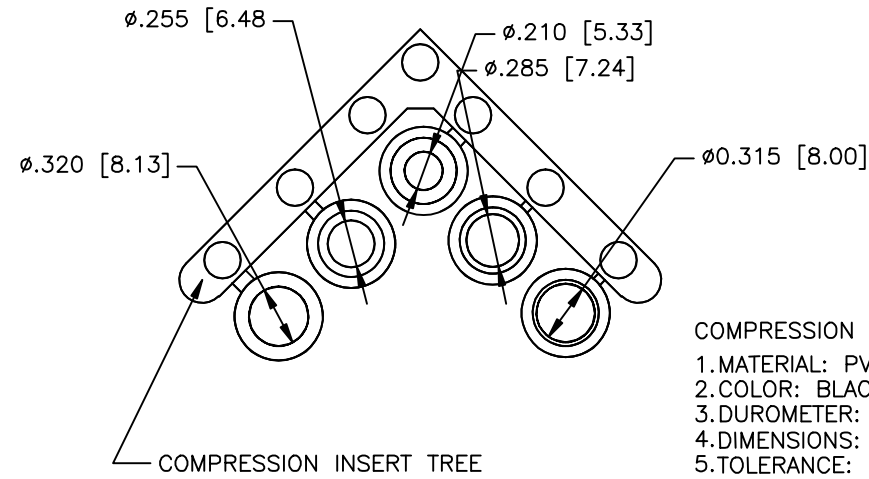

- COMPRESSION INSERT TREE
- 1.MATERIAL: PVC UL94V-0
 - 2.COLOR: BLACK
 - 3.DUROMETER: 80 ±3 TYPE A PER ASTM D2240
 - 4.DIMENSIONS: INCHES [MM]
 - 5.TOLERANCE: ±0.020 [0.508]

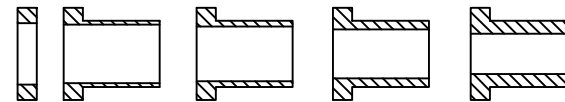

NO LOGO



PART NUMBER INFORMATION

PART#	FINISH	STRAIN RELIEF SYSTEM	DESCRIPTION	SUPPLIED
NA95E200000SM3	NICKEL	JACKET INSERT TREE	NOLOGO TOP	BULK
NA95E200100	NICKEL	JACKET INSERT TREE	BOTTOM	BULK
N95E200000SM3	NICKEL	JACKET INSERT TREE	NOLOGO	PACKAGED
NA95E200000M3	NICKEL	COMPRESSION INSERT TREE	NOLOGO TOP	BULK
NA95E200100	NICKEL	COMPRESSION INSERT TREE	BOTTOM	BULK
N95E200000M3	NICKEL	COMPRESSION INSERT TREE	NOLOGO	PACKAGED
A95E200000SM3	ZINC	JACKET INSERT TREE	NO LOGO TOP	OBSOLETE
A95E200100	ZINC	JACKET INSERT TREE	BOTTOM	OBSOLETE
C95E200000SM3	ZINC	JACKET INSERT TREE	NO LOGO	OBSOLETE
A95E200000M3	ZINC	COMPRESSION INSERT TREE	NO LOGO TOP	OBSOLETE
A95E200100	ZINC	COMPRESSION INSERT TREE	BOTTOM	OBSOLETE
C95E200000M3	ZINC	COMPRESSION INSERT TREE	NO LOGO	OBSOLETE

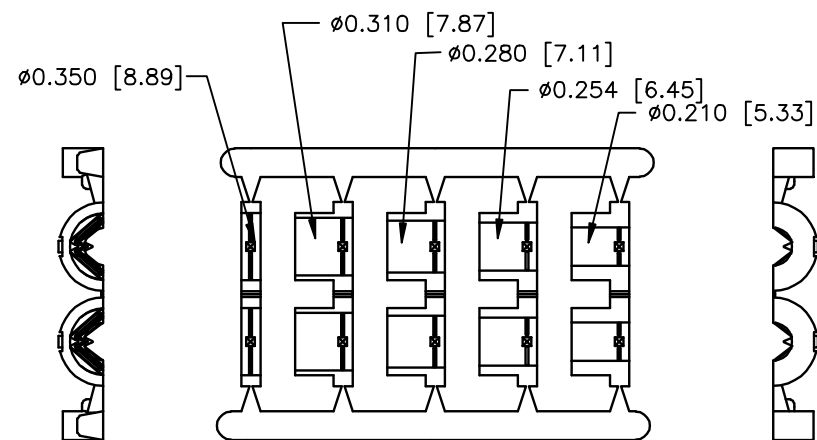

- JACKET INSERT TREE
- 1.MATERIAL: POLYPROPYLENE UL94HB
 - 2.COLOR: BLACK
 - 3.DIMENSIONS: INCHES [MM]
 - 4.TOLERANCE: ±0.010 [0.254]

THIS IS A CONTROLLED DOCUMENT AND IS SUBJECT TO CHANGE. CONTACT NORTHERN TECHNOLOGIES ENGINEERING FOR THE LATEST REVISION.

UNLESS OTHERWISE SPECIFIED		Northern Technologies <small>THIS DRAWING IS THE PROPERTY OF NORTHERN TECHNOLOGIES AND SHOULD NOT BE REPRODUCED WITHOUT NORTHERN TECHNOLOGIES WRITTEN PERMISSION.</small>		
1. ALL DIMENSIONS ARE IN INCHES [MM] 2. DIMENSIONS ARE TYPICAL				
DRAWN Luis C.		PART NUMBER SEE ORDER INFORMATION		
25-FEB-11		DESCRIPTION CM 09 45D EXIT w/ M3 THUMBSCREWS		
CHECKED JSD	25-FEB-11	SIZE B	CODE 200_239M3	DWG NO. 0002-200-239M3
ISSUED	25-FEB-11	SCALE NTS		REV
				SHEET 2 OF 2