

REV	DATE	DESCRIPTION	APP

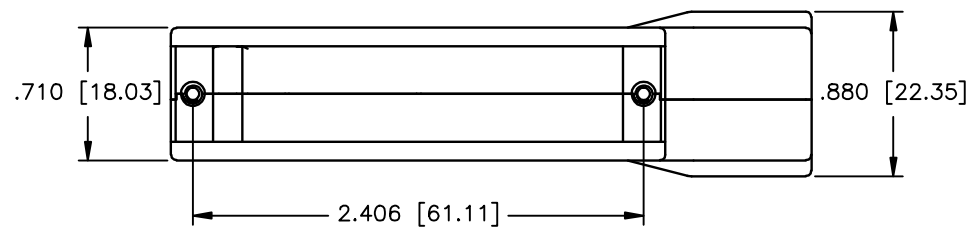

NO LOGO

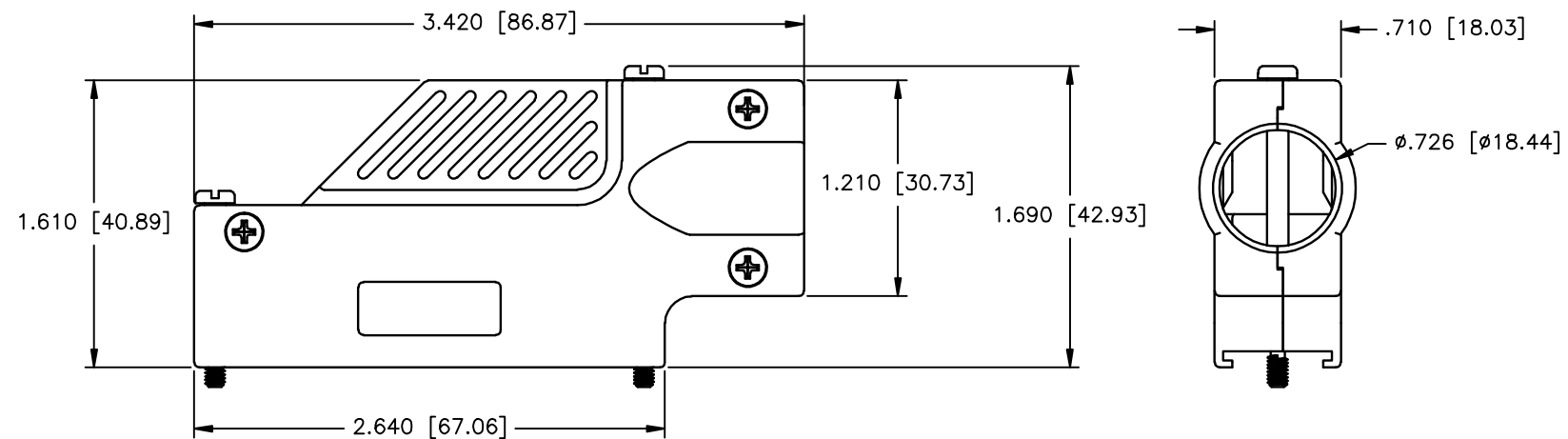

PART NUMBER INFORMATION

PART#	LOGO STYLE	SUPPLIED
NA30E940000LTM3	NO LOGO TOP COVER	BULK
NA30E940100L	BOTTOM COVER	BULK
N30E940000LTM3	NO LOGO	PACKAGED

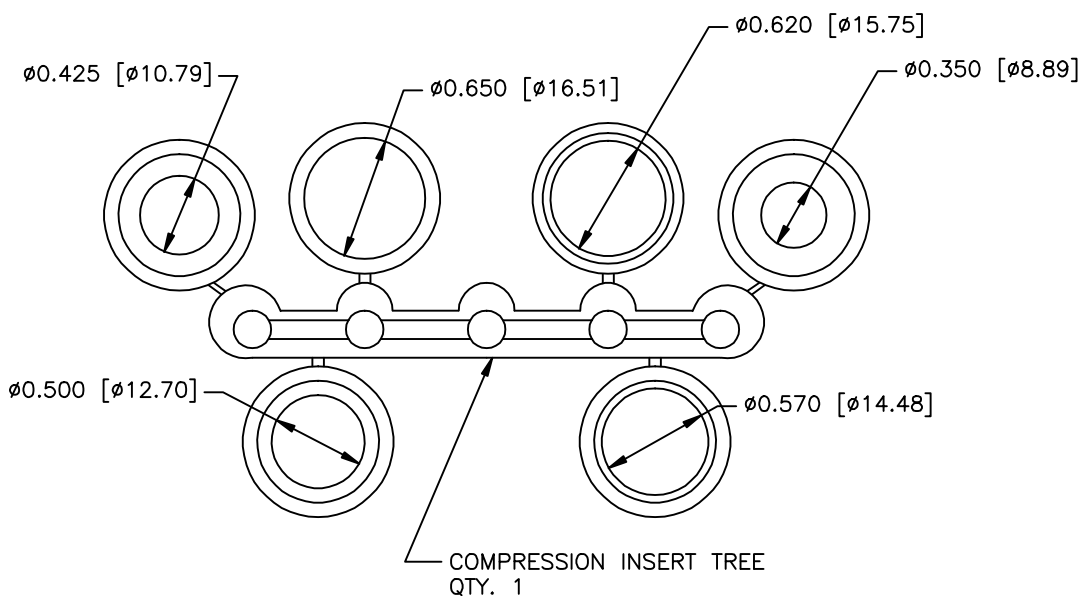

#4-40 X 0.5" PHILLIPS HEAD MACHINE SCREW  
- STAINLESS STEEL  
QTY: 3 EACH

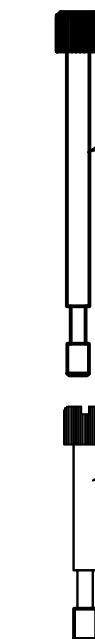

M3 X 1.36" THUMBSCREW  
- STEEL, NICKEL PLATED  
QTY: 1 EACH

M3 X 1.23" THUMBSCREW  
- STEEL, NICKEL PLATED  
QTY: 1 EACH

CONNECTOR COVER:

- 1.MATERIAL: ZINC ALLOY
- 2.FINISH: NICKEL PLATING PER NTC SPECIFICATION N/T 000400
- 3.DIMENSIONS: INCHES [MM]
- 4.TOLERANCE: ±0.015 [0.381]

COMPRESSION INSERT TREE

- 1.MATERIAL: THERMOPLASTIC
- 2.COLOR: BLACK
- 3.DUROMETER: 75 ±5 TYPE A PER ASTM D2240
- 4.DIMENSIONS: INCHES [MM]
- 5.TOLERANCE: ±0.020 [0.508]

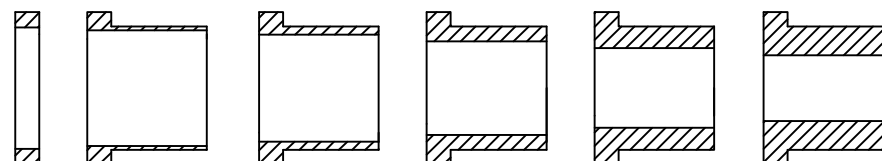

THIS IS A CONTROLLED DOCUMENT AND IS SUBJECT TO CHANGE. CONTACT NORTHERN TECHNOLOGIES ENGINEERING FOR THE LATEST REVISION.

UNLESS OTHERWISE SPECIFIED	SIGNATURES	DATE	Northern Technologies		
1. ALL DIMENSIONS ARE IN INCHES (MM) 2. DIMENSIONS ARE TYPICAL	DRAWN JSD	16-JAN-14	PART NUMBER SEE PART NUMBER INFORMATION DESCRIPTION CM 50 90 DEGREE LOW PROFILE COVER WITH M3 THUMBSCREWS		
	CHECKED SCN	16-JAN-14			
	ISSUED	16-JAN-14	SHEET 1	CODE 200_233TM3	DWG NO. 0002-200-233TM3
	SCALE N.T.S.			SHEET 1 OF 1	

THIS DRAWING IS THE PROPERTY OF NORTHERN TECHNOLOGIES AND SHOULD NOT BE REPRODUCED WITHOUT NORTHERN TECHNOLOGIES WRITTEN PERMISSION.