

REVISIONS				
ZONE	REV	DESCRIPTION	DATE	APPROVED
	A	ECN0773A	09-JUN-15	

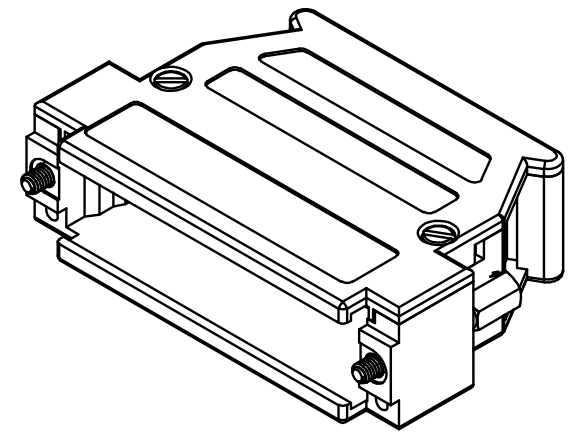
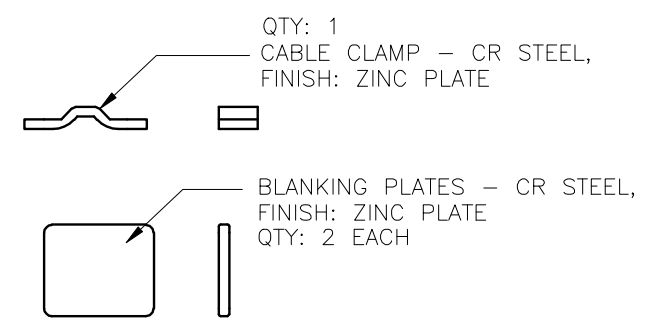
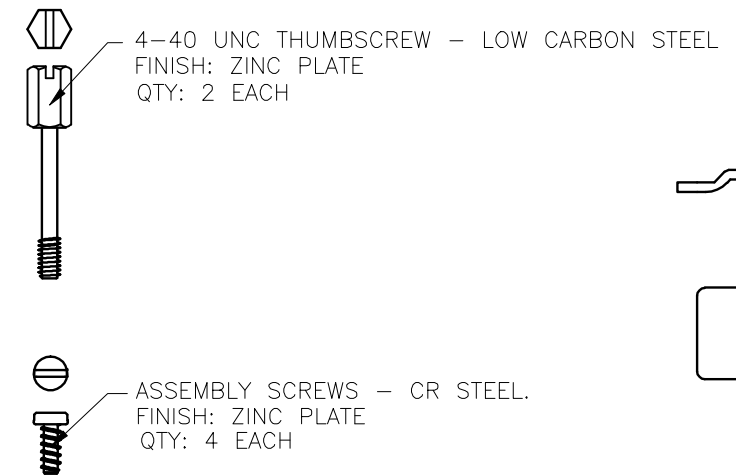
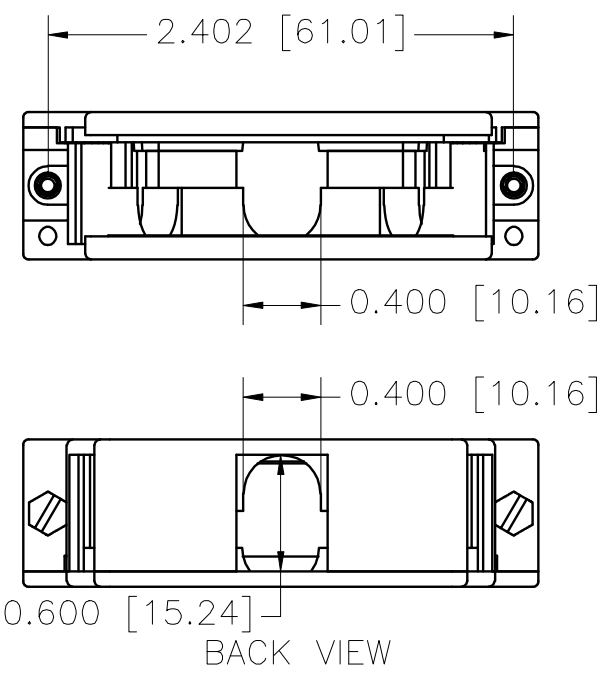
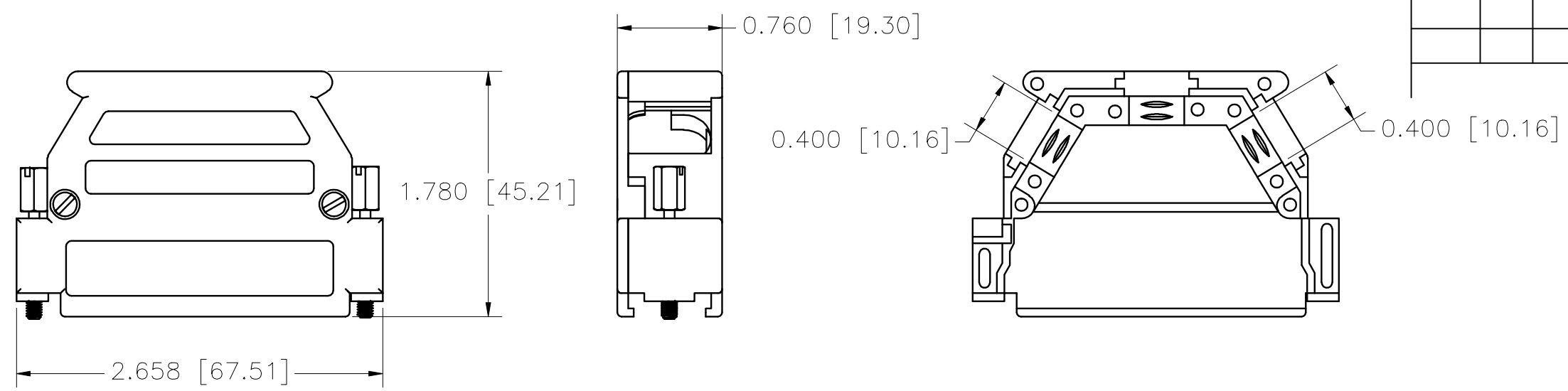

PART NUMBER INFORMATION

PART#	LOGO STYLE	SUPPLIED
MHDE3MK50KS	NO LOGO	PACKAGED

CONNECTOR COVER:
 1.MATERIAL: PLATING GRADE ABS
 2.FINISH: NICKEL OVER COPPER UNDER-PLATE
 3.DIMENSIONS: INCHES [MM]
 4.TOLERANCE: ±0.015 [0.381]

DISCONTINUED

THIS IS A CONTROLLED DOCUMENT AND IS SUBJECT TO CHANGE. CONTACT NORTHERN TECHNOLOGIES ENGINEERING FOR THE LATEST REVISION.

UNLESS OTHERWISE SPECIFIED 1. ALL DIMENSIONS ARE IN INCHES [MM] 2. DIMENSIONS ARE TYPICAL		Northern Technologies <small>THIS DRAWING IS THE PROPERTY OF NORTHERN TECHNOLOGIES AND SHOULD NOT BE REPRODUCED WITHOUT NORTHERN TECHNOLOGIES' WRITTEN PERMISSION.</small>		
DRAWN Luis C. 16-JUL-08		PART NUMBER SEE PART NUMBER INFORMATION DESCRIPTION CMP3 50 3 WAY EXIT METALIZED PLASTIC COVER		
CHECKED JSD 16-JUL-08	ISSUED 25-JUL-08	SIZE B	CODE 200_220	DWG NO. 0002-200-220
		SCALE NTS	SHEET 1 OF 1	