

THIS PRODUCT IS
DISCONTINUED

REVISIONS				
ZONE	REV	DESCRIPTION	DATE	APPROVED
	A	ECN 0578	06-OCT-05	
	B	ECN 0603	10-AUG-06	
	C	ECN 0755	12-NOV-14	
	D	ECN 0847	19-FEB-24	

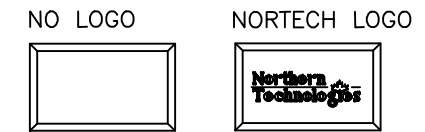
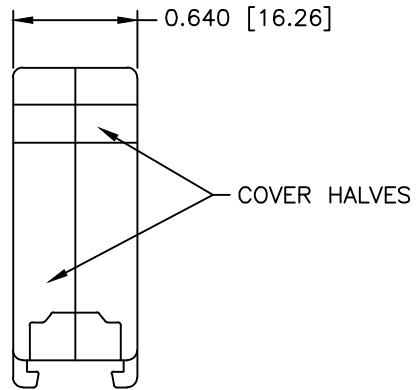
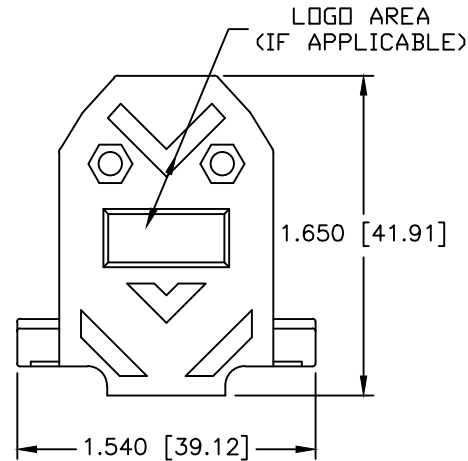

PART NUMBER INFORMATION

PART#	LOGO STYLE	SUPPLIED
F30E310000	NO LOGO	BULK
F88E310000	NO LOGO	PACKAGED
F30E311000	NORTECH LOGO*	BULK
F88E311000	NORTECH LOGO*	PACKAGED

* - SPECIAL ORDER ITEM - CONTACT NORTHERN TECHNOLOGIES

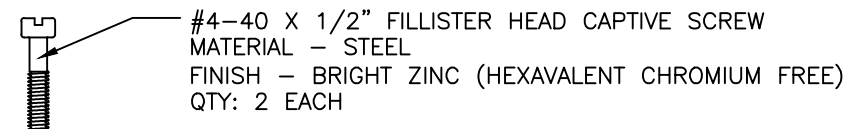
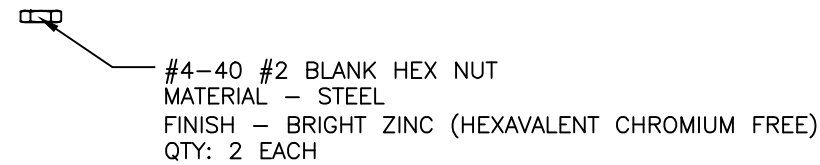
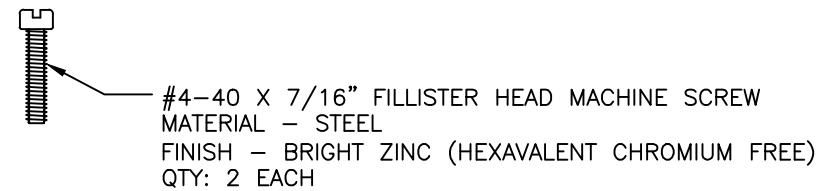
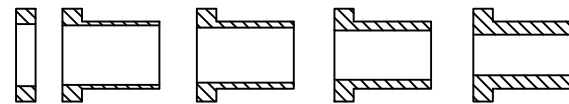
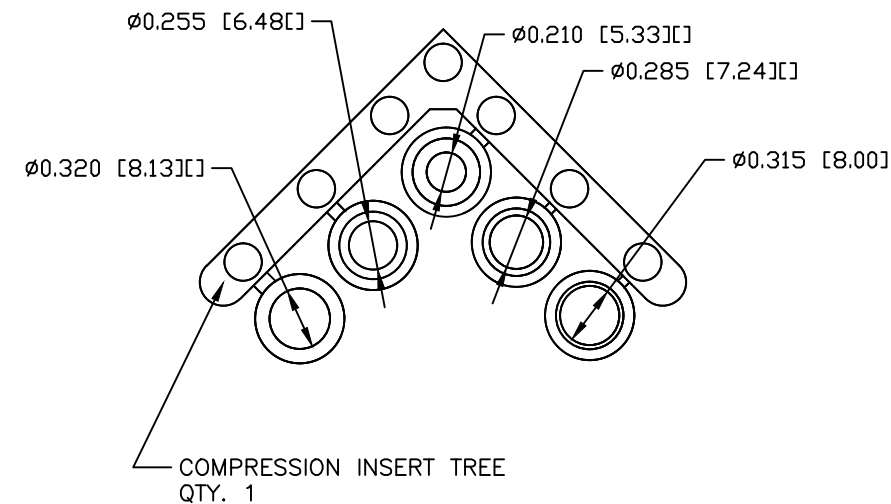

CONNECTOR COVER:

- 1.MATERIAL: ABS COMPOUND UL94V-0
- 2.FINISH: NICKEL PLATING PER NTC SPECIFICATION N/T 000500
- 3.DIMENSIONS: INCHES [MM]
- 4.TOLERANCE: ±0.015 [0.381]

COMPRESSION INSERT TREE

- 1.MATERIAL: THERMOPLASTIC 94V-0
- 2.COLOR: BLACK
- 3.DUROMETER: 75 ±5 TYPE A PER ASTM D2240
- 4.DIMENSIONS: INCHES [MM]
- 5.TOLERANCE: ±0.020 [0.508]

THIS IS A CONTROLLED DOCUMENT AND IS SUBJECT TO CHANGE. CONTACT NORTHERN TECHNOLOGIES ENGINEERING FOR THE LATEST REVISION.

UNLESS OTHERWISE SPECIFIED

1. ALL DIMENSIONS ARE IN INCHES (MM)
2. DIMENSIONS ARE TYPICAL

Northern Technologies

THIS DRAWING IS THE PROPERTY OF NORTHERN TECHNOLOGIES AND SHOULD NOT BE REPRODUCED WITHOUT NORTHERN TECHNOLOGIES WRITTEN PERMISSION.

PART NUMBER SEE PART NUMBER INFORMATION

DESCRIPTION CMP 15 STR EXIT TWO PIECE METALIZED PLASTIC COVER FR

DRAWN JSD	01-JUL-05	SIZE B	CODE 200_210	DWG NO. 0002-200-210	REV D
CHECKED SCN	01-JUL-05	SCALE 1:1		SHEET 1 OF 1	
ISSUED	01-JUL-05				