

REV	DATE	DESCRIPTION	APP

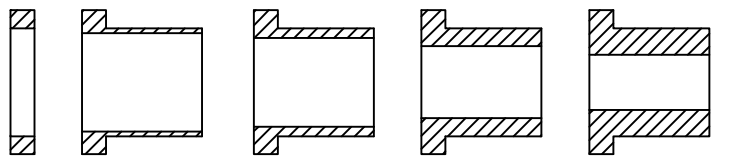
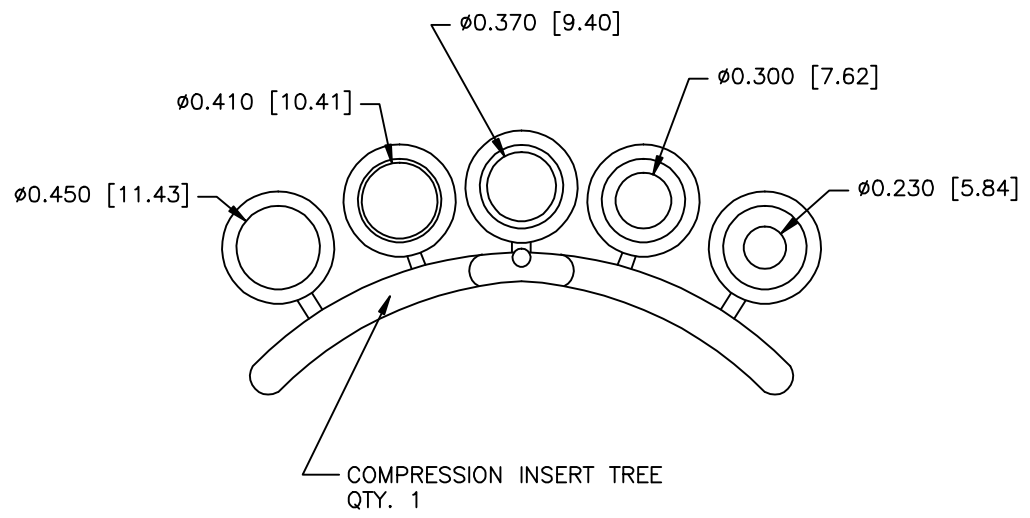
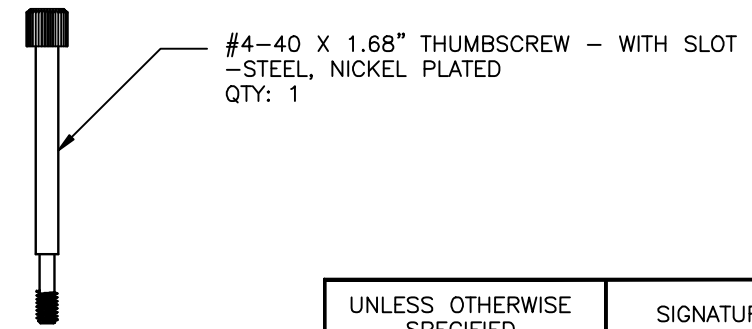
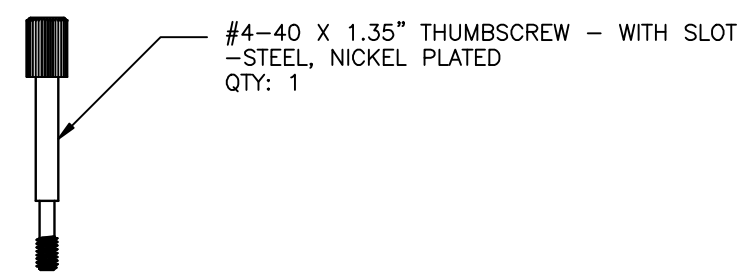
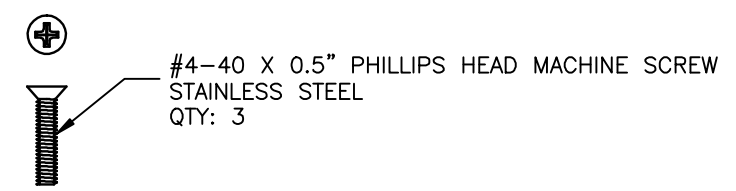
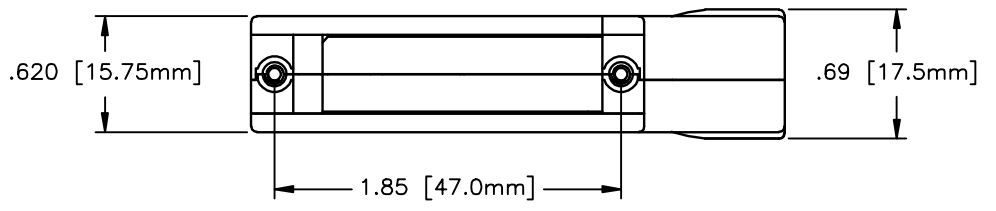
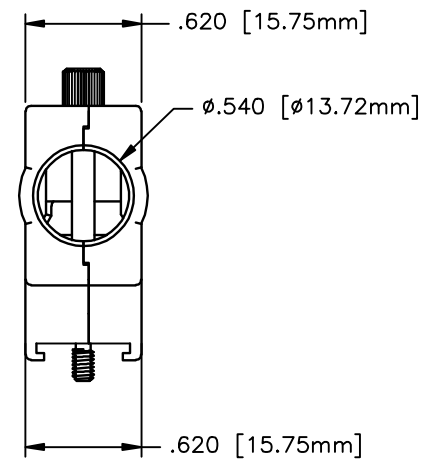
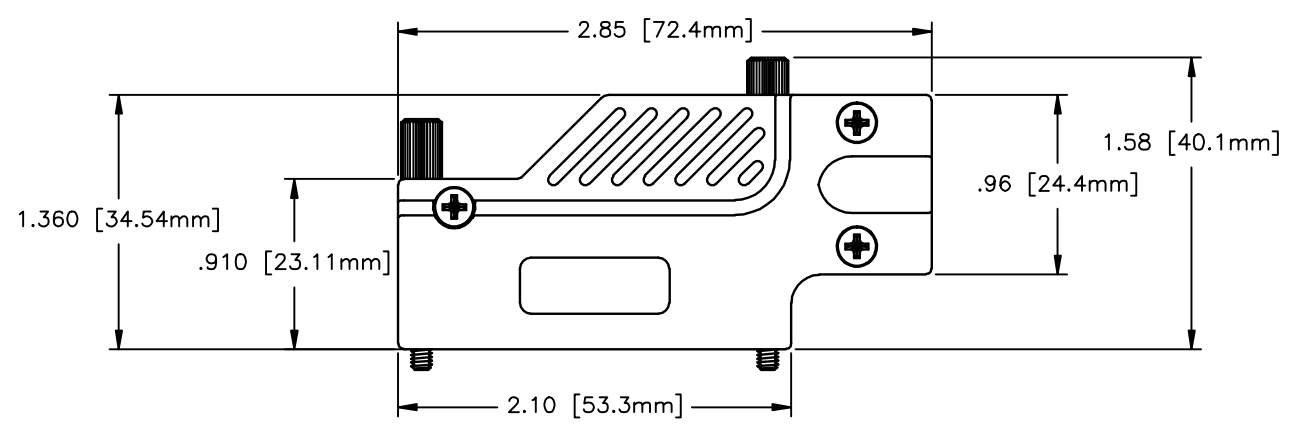

THIS IS A CONTROLLED DOCUMENT AND IS SUBJECT TO CHANGE. CONTACT NORTHERN TECHNOLOGIES ENGINEERING FOR THE LATEST REVISION.

NO LOGO

PART NUMBER INFORMATION

PART#	LOGO STYLE	SUPPLIED
NA30E920000T1	NO LOGO TOP COVER	BULK
NA30E920100	BOTTOM COVER	BULK
N30E920000T1	NO LOGO	PACKAGED

CONNECTOR COVER:
 1. MATERIAL: ZINC ALLOY
 2. FINISH: NICKEL PLATING PER NTC SPECIFICATION N/T 000400
 3. DIMENSIONS: INCHES [MM]
 4. TOLERANCE: ± 0.015 [0.381]

COMPRESSION INSERT TREE
 1. MATERIAL: THERMOPLASTIC
 2. COLOR: BLACK
 3. DUROMETER: 75 ± 5 TYPE A PER ASTM D2240
 4. DIMENSIONS: INCHES [MM]
 5. TOLERANCE: ± 0.020 [0.508]

UNLESS OTHERWISE SPECIFIED	SIGNATURES	DATE	Northern Technologies	
1. ALL DIMENSIONS ARE IN INCHES (MM) 2. DIMENSIONS ARE TYPICAL	DRAWN JSD	16-SEP-10	THIS DRAWING IS THE PROPERTY OF NORTHERN TECHNOLOGIES AND SHOULD NOT BE REPRODUCED WITHOUT NORTHERN TECHNOLOGIES WRITTEN PERMISSION.	
	CHECKED SCN	16-SEP-10	PART NUMBER SEE PART NUMBER INFORMATION	
	ISSUED	16-SEP-10	DESCRIPTION CM 25 90 DEGREE ULTRA LOW PROFILE WITH DUAL THUMBSCREW	
			SHEET 1	CODE 200_207T1
				DWG NO. 0002-200-207T1
			SCALE N.T.S.	SHEET 1 OF 1