

REV	DATE	DESCRIPTION	APP
A	12-NOV-14	ECN 0755	

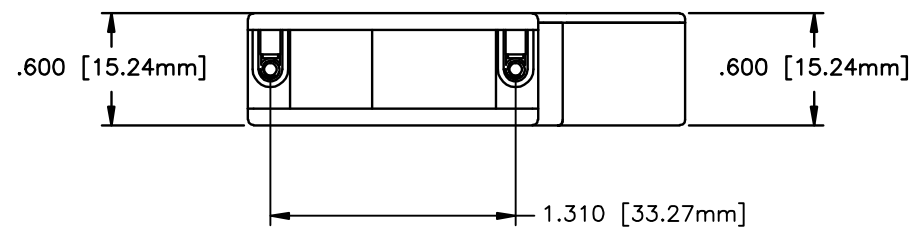

NO LOGO

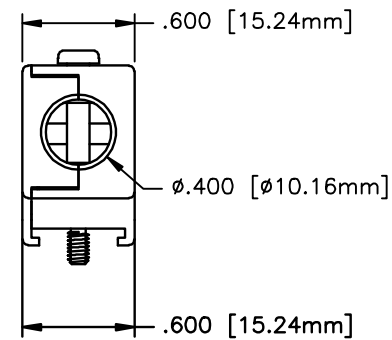
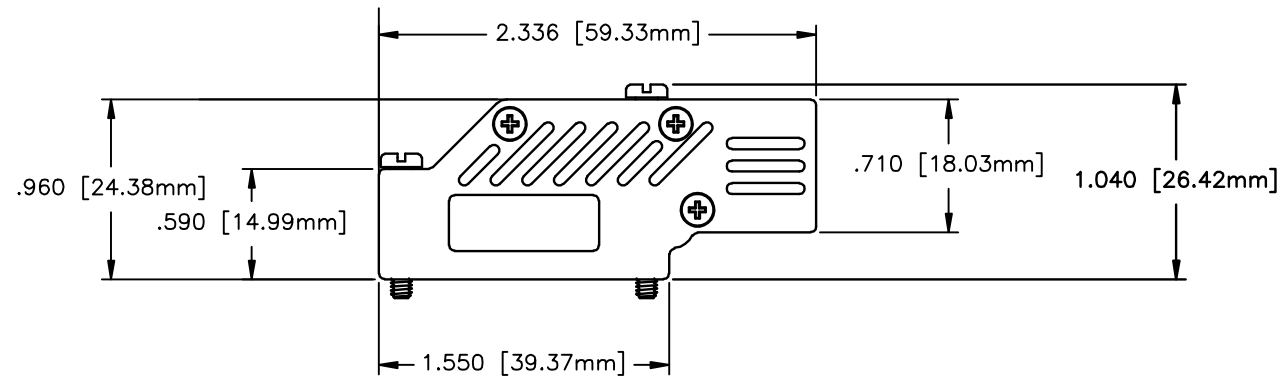

PART NUMBER INFORMATION

PART#	LOGO STYLE	SUPPLIED
NA30E910000	NO LOGO TOP COVER	BULK
NA30E910100	BOTTOM COVER	BULK
N30E910000	NO LOGO	PACKAGED



#2-56 PHILLIPS HEAD MACHINE SCREW
- STAINLESS STEEL
QTY.: 3 EACH

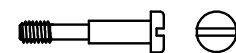

#4-40 X 0.770" SLOTTED CAPTIVE SCREW
- LOW CARBON STEEL, NICKEL PLATED
QTY.: 1 EACH

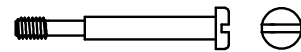

#4-40 X 1.140" SLOTTED CAPTIVE SCREW
- LOW CARBON STEEL, NICKEL PLATED
QTY.: 1 EACH

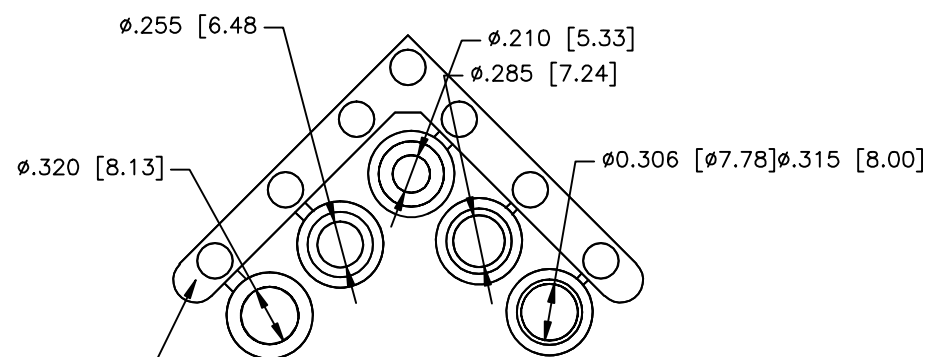

COMPRESSION INSERT TREE
QTY. 1

CONNECTOR COVER:

- 1.MATERIAL: ZINC ALLOY
- 2.FINISH: NICKEL PLATING PER NTC SPECIFICATION N/T 000400
- 3.DIMENSIONS: INCHES [MM]
- 4.TOLERANCE: ±0.015 [0.381]

COMPRESSION INSERT TREE

- 1.MATERIAL: THERMOPLASTIC
- 2.COLOR: BLACK
- 3.DUROMETER: 75 ±5 TYPE A PER ASTM D2240
- 4.DIMENSIONS: INCHES [MM]
- 5.TOLERANCE: ±0.020 [0.508]

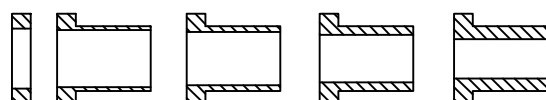

THIS IS A CONTROLLED DOCUMENT AND IS SUBJECT TO CHANGE. CONTACT NORTHERN TECHNOLOGIES ENGINEERING FOR THE LATEST REVISION.

UNLESS OTHERWISE SPECIFIED	SIGNATURES	DATE	Northern Technologies		
1. ALL DIMENSIONS ARE IN INCHES (MM) 2. DIMENSIONS ARE TYPICAL	DRAWN JSD	02-JAN-06	THIS DRAWING IS THE PROPERTY OF NORTHERN TECHNOLOGIES AND SHOULD NOT BE REPRODUCED WITHOUT NORTHERN TECHNOLOGIES WRITTEN PERMISSION. PART NUMBER SEE PART NUMBER INFORMATION DESCRIPTION CM 15 90 DEGREE ULTRA LOW PROFILE		
	CHECKED SCN	02-JAN-06			
	ISSUED	02-JAN-06	SHEET 1	CODE 200_206	DWG NO. 0002-200-206
				SCALE N.T.S.	SHEET 1 OF 1