

REVISIONS				
ZONE	REV	DESCRIPTION	DATE	APPROVED

NO LOGO

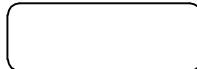

PART NUMBER INFORMATION

PART#	LOGO STYLE	SUPPLIED
NA30E930000LTM3	NO LOGO TOP COVER	BULK
NA30E930100L	BOTTOM COVER	BULK
N30E930000LTM3	NO LOGO	PACKAGED

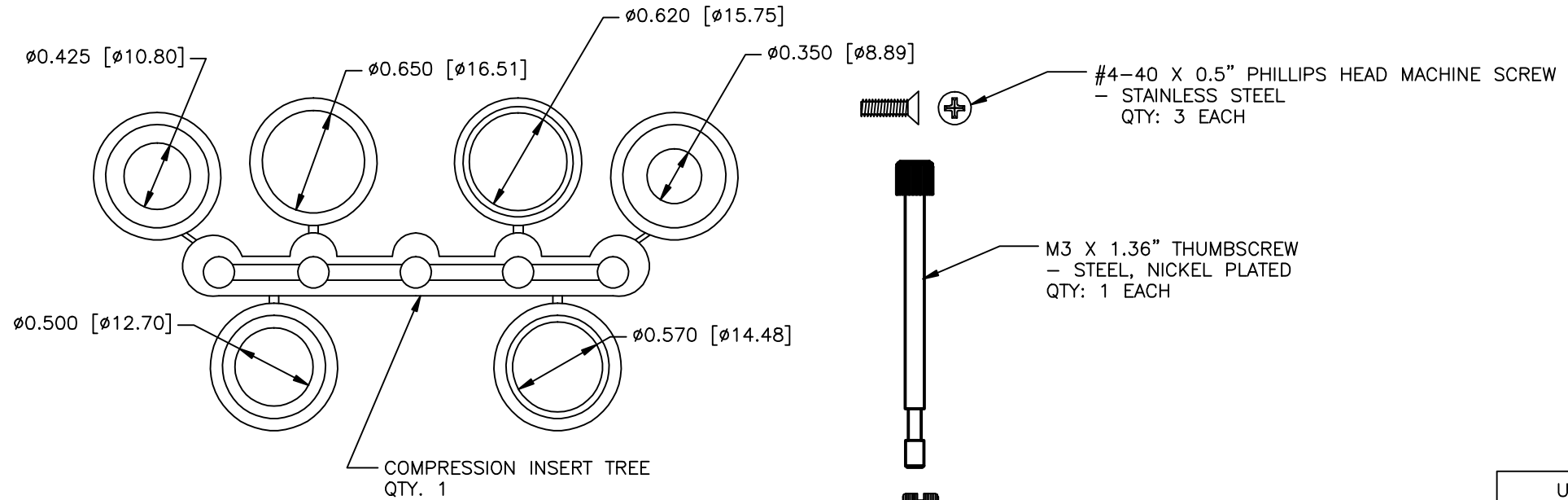
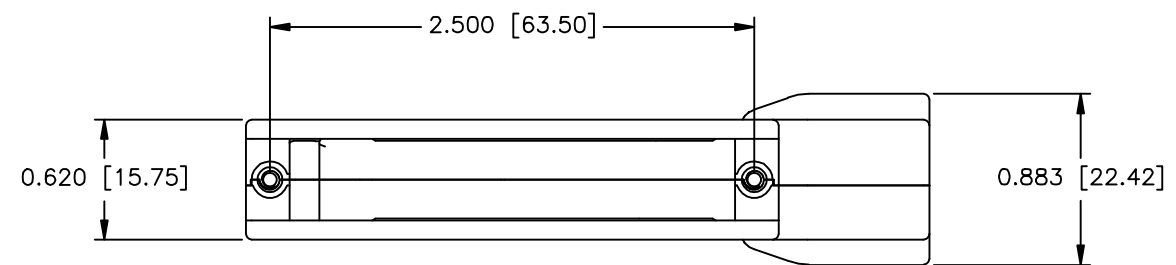

CONNECTOR COVER:

- 1.MATERIAL: ZINC ALLOY
- 2.FINISH: NICKEL PLATING PER NTC SPECIFICATION N/T 000400
- 3.DIMENSIONS: INCHES [MM]
- 4.TOLERANCE: ±0.015 [0.381]

COMPRESSION INSERT TREE

- 1.MATERIAL: THERMOPLASTIC
- 2.COLOR: BLACK
- 3.DUROMETER: 75 ±5 TYPE A PER ASTM D2240
- 4.DIMENSIONS: INCHES [MM]
- 5.TOLERANCE: ±0.020 [0.508]

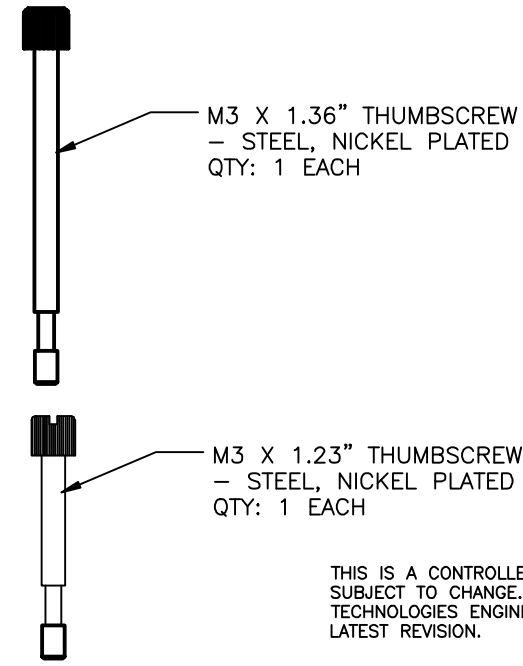
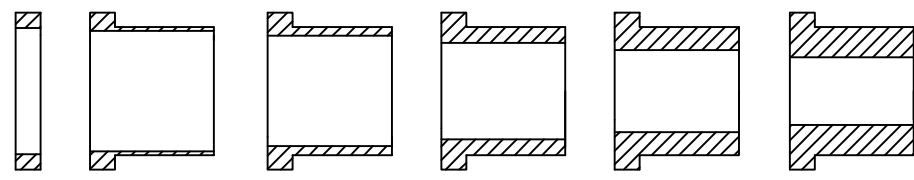

THIS IS A CONTROLLED DOCUMENT AND IS SUBJECT TO CHANGE. CONTACT NORTHERN TECHNOLOGIES ENGINEERING FOR THE LATEST REVISION.

UNLESS OTHERWISE SPECIFIED		Northern Technologies <small>THIS DRAWING IS THE PROPERTY OF NORTHERN TECHNOLOGIES AND SHOULD NOT BE REPRODUCED WITHOUT NORTHERN TECHNOLOGIES WRITTEN PERMISSION.</small>		
1. ALL DIMENSIONS ARE IN INCHES (MM) 2. DIMENSIONS ARE TYPICAL				
DRAWN JSD 16-JAN-14		PART NUMBER SEE PART NUMBER INFORMATION		
CHECKED SCN 16-JAN-14		DESCRIPTION CM 37 90 DEGREE LOW PROFILE COVER WITH M3 THUMBSCREWS		
ISSUED 16-JAN-14		SIZE B	CODE 200_204TM3	DWG NO. 0002-200-204TM3
		SCALE N.T.S.		REV
				SHEET 1 OF 1