

REVISIONS				
ZONE	REV	DESCRIPTION	DATE	APPROVED

NO LOGO



PART NUMBER INFORMATION

PART#	LOGO STYLE	SUPPLIED
NA30E930000LM3	NO LOGO TOP COVER	BULK
NA30E930100L	BOTTOM COVER	BULK
N30E930000LM3	NO LOGO	PACKAGED

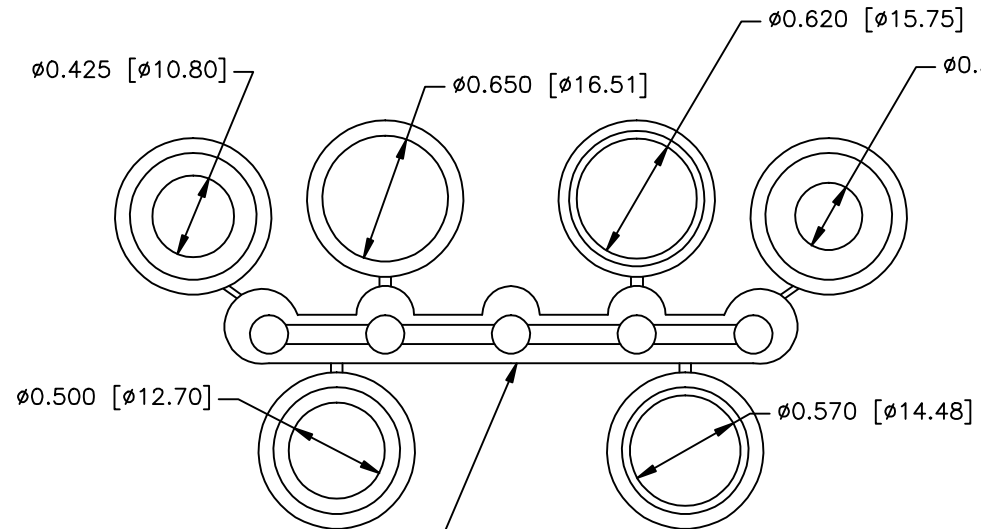
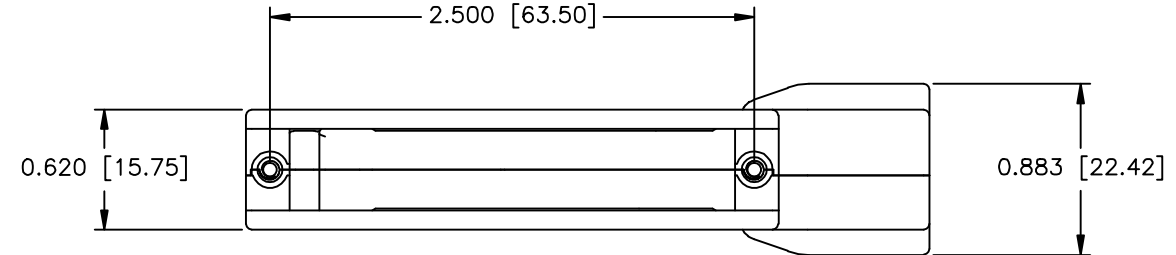

#4-40 X 0.5" PHILLIPS HEAD MACHINE SCREW  
- STAINLESS STEEL  
QTY: 3 EACH

M3 X 1.80" SLOTTED MATING SCREW  
- STEEL, NICKEL PLATED  
QTY: 1 EACH

M3 X 1.10" SLOTTED MATING SCREW  
- STEEL, NICKEL PLATED  
QTY: 1 EACH

CONNECTOR COVER:

- 1.MATERIAL: ZINC ALLOY
- 2.FINISH: NICKEL PLATING PER NTC SPECIFICATION N/T 000400
- 3.DIMENSIONS: INCHES [MM]
- 4.TOLERANCE: ±0.015 [0.381]

COMPRESSION INSERT TREE

- 1.MATERIAL: THERMOPLASTIC
- 2.COLOR: BLACK
- 3.DUROMETER: 75 ±5 TYPE A PER ASTM D2240
- 4.DIMENSIONS: INCHES [MM]
- 5.TOLERANCE: ±0.020 [0.508]

COMPRESSION INSERT TREE  
QTY. 1

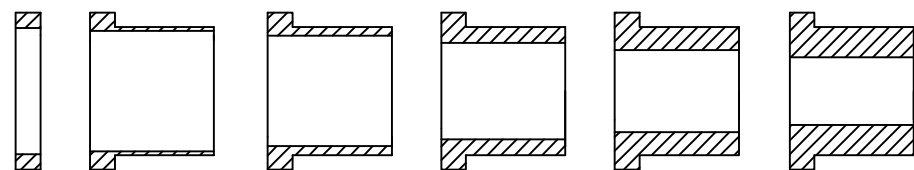

THIS IS A CONTROLLED DOCUMENT AND IS SUBJECT TO CHANGE. CONTACT NORTHERN TECHNOLOGIES ENGINEERING FOR THE LATEST REVISION.

UNLESS OTHERWISE SPECIFIED		<b>Northern Technologies</b> <small>THIS DRAWING IS THE PROPERTY OF NORTHERN TECHNOLOGIES AND SHOULD NOT BE REPRODUCED WITHOUT NORTHERN TECHNOLOGIES WRITTEN PERMISSION.</small>		
1. ALL DIMENSIONS ARE IN INCHES (MM) 2. DIMENSIONS ARE TYPICAL				
DRAWN JSD 16-JAN-14		PART NUMBER SEE PART NUMBER INFORMATION		
CHECKED SCN 16-JAN-14		DESCRIPTION CM 37 90 DEGREE LOW PROFILE COVER WITH M3 MATING SCREWS		
ISSUED	16-JAN-14	SIZE B	CODE 200_204M3	DWG NO. 0002-200-204M3
		SCALE N.T.S.	SHEET 1 OF 1	