

REVISIONS				
ZONE	REV	DESCRIPTION	DATE	APPROVED

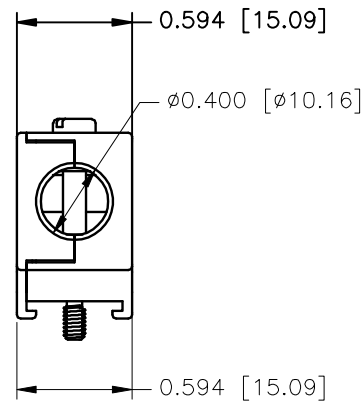

NO LOGO

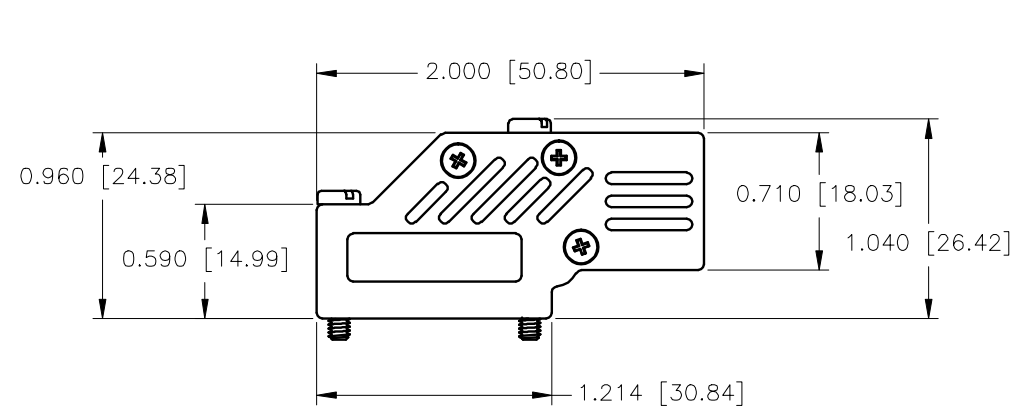
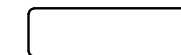

PART NUMBER INFORMATION

PART#	LOGO STYLE	SUPPLIED
NA30E900000M3	NO LOGO TOP COVER	BULK
NA30E900100	BOTTOM COVER	BULK
N30E900000M3	NO LOGO	PACKAGED

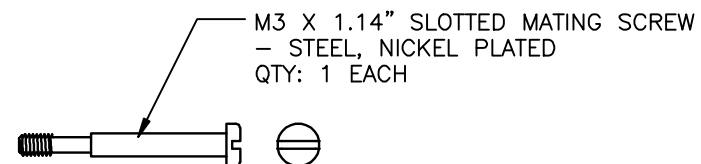
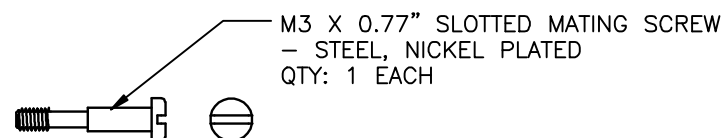
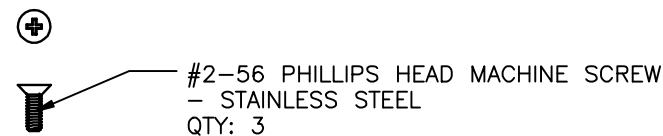
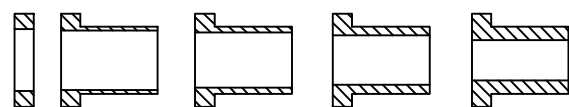
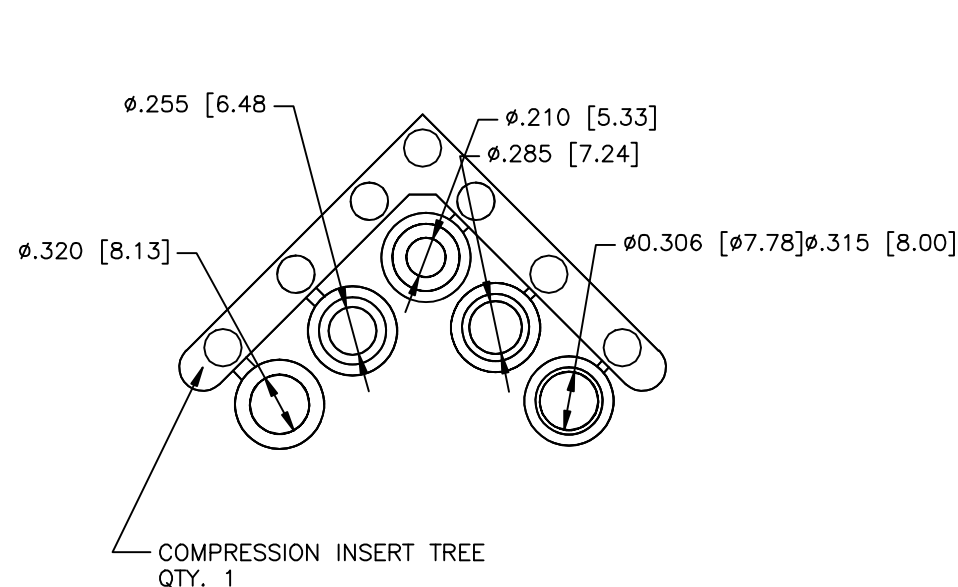
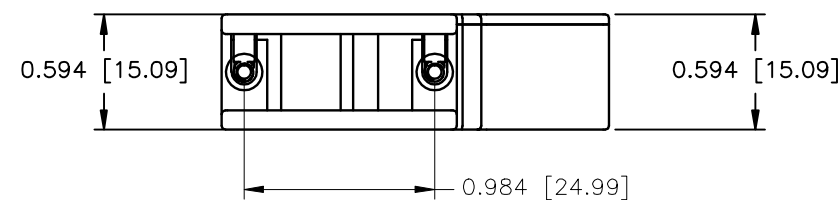

CONNECTOR COVER:

- 1.MATERIAL: ZINC ALLOY
- 2.FINISH: NICKEL PLATING PER NTC SPECIFICATION N/T 000400
- 3.DIMENSIONS: INCHES [MM]
- 4.TOLERANCE: ±0.015 [0.381]

COMPRESSION INSERT TREE

- 1.MATERIAL: THERMOPLASTIC
- 2.COLOR: BLACK
- 3.DUROMETER: 75 ±5 TYPE A PER ASTM D2240
- 4.DIMENSIONS: INCHES [MM]
- 5.TOLERANCE: ±0.020 [0.508]

THIS IS A CONTROLLED DOCUMENT AND IS SUBJECT TO CHANGE. CONTACT NORTHERN TECHNOLOGIES ENGINEERING FOR THE LATEST REVISION.

UNLESS OTHERWISE SPECIFIED 1. ALL DIMENSIONS ARE IN INCHES (MM) 2. DIMENSIONS ARE TYPICAL		Northern Technologies		
DRAWN JSD		PART NUMBER SEE PART NUMBER INFORMATION		
29-APR-11		DESCRIPTION CM 09 90 DEGREE ULTRA LOW PROFILE WITH M3 MATING SCREWS		
CHECKED SCN	29-APR-11	SIZE B	CODE 200_169M3	DWG NO. 0002-200-169M3
ISSUED	29-APR-11	SCALE N.T.S.		REV
				SHEET 1 OF 1