

REVISIONS				
ZONE	REV	DESCRIPTION	DATE	APPROVED
	A	ECN 0607	10-AUG-06	

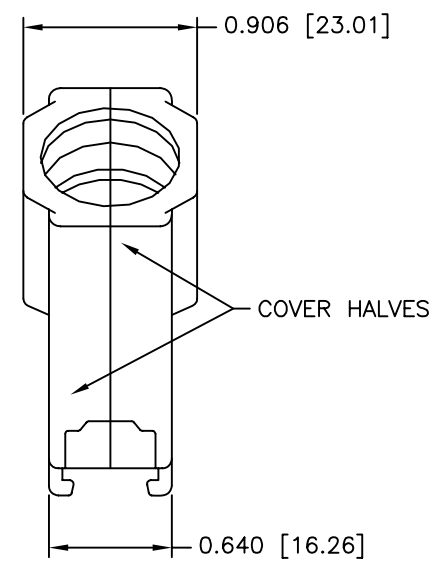
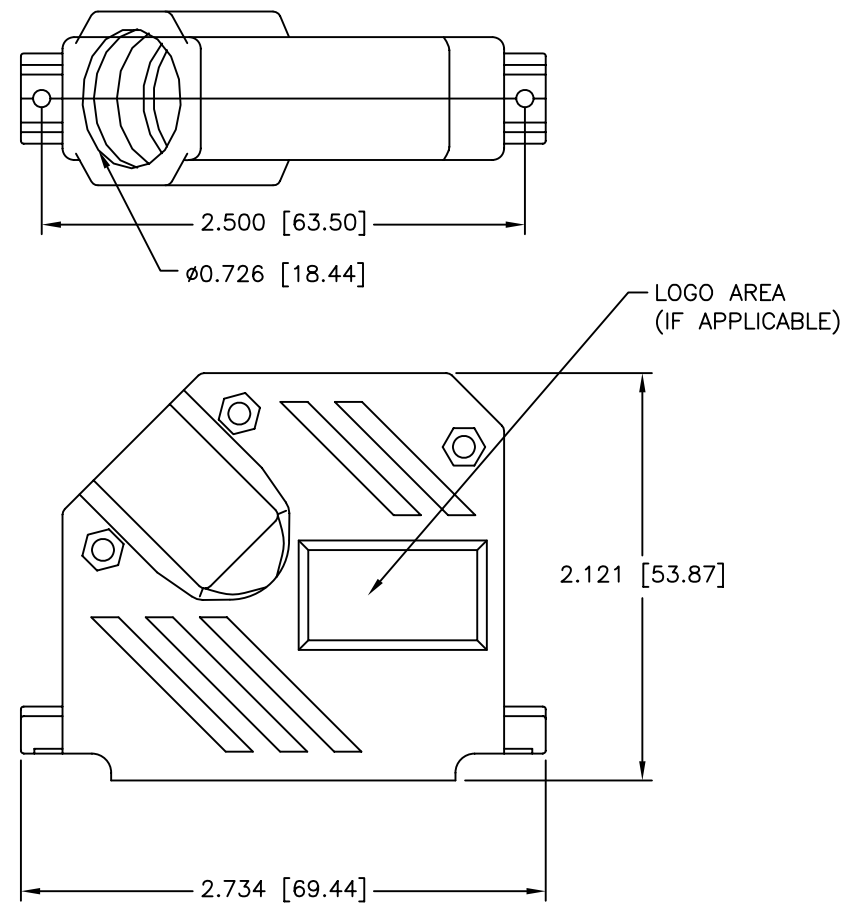

PART NUMBER INFORMATION
COLOR: BLACK

PART#	LOGO STYLE	SUPPLIED
A30E230004	NO LOGO	BULK
C88E230004	NO LOGO	PACKAGED
A30E231004	NORTECH LOGO*	BULK
C88E231004	NORTECH LOGO*	PACKAGED

COLOR: GRAY

PART#	LOGO STYLE	SUPPLIED
A30E230005	NO LOGO	BULK
C88E230005	NO LOGO	PACKAGED
A30E231005	NORTECH LOGO*	BULK
C88E231005	NORTECH LOGO*	PACKAGED

* - SPECIAL ORDER ITEM - CONTACT NORTHERN TECHNOLOGIES

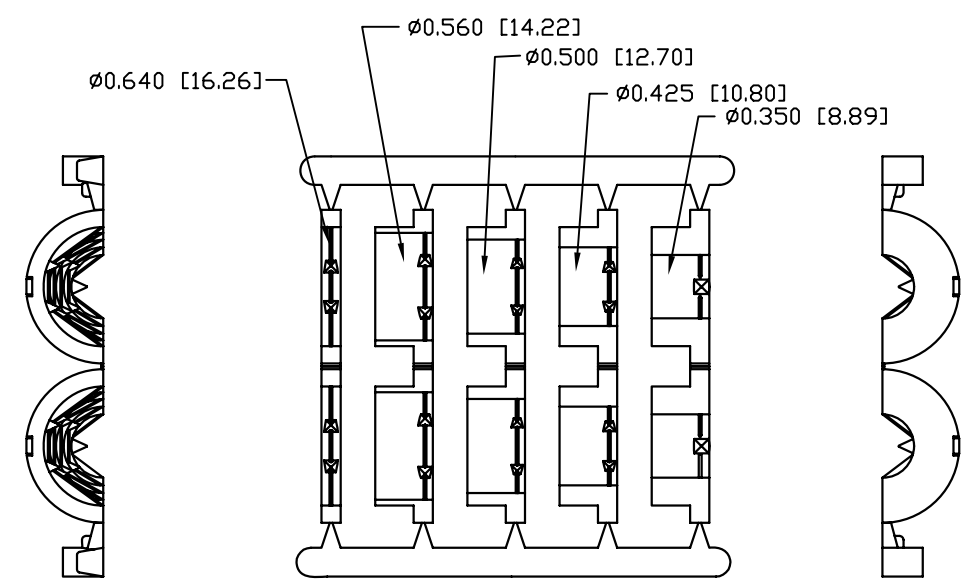

JACKET INSERT TREE
QTY: 1

- #4-40 X 7/16" FILLISTER HEAD MACHINE SCREW
MATERIAL - STEEL
FINISH - BRIGHT ZINC (HEXAVALENT CHROMIUM FREE)
QTY: 3 EACH
- #4-40 #2 BLANK HEX NUT
MATERIAL - STEEL
FINISH - BRIGHT ZINC (HEXAVALENT CHROMIUM FREE)
QTY: 3 EACH
- #4-40 X 1/2" FILLISTER HEAD CAPTIVE SCREW
MATERIAL - STEEL
FINISH - BRIGHT ZINC (HEXAVALENT CHROMIUM FREE)
QTY: 2 EACH
- #4 SADDLE WASHER
MATERIAL - STEEL
FINISH - BRIGHT ZINC (HEXAVALENT CHROMIUM FREE)
QTY: 2 EACH

CONNECTOR COVER:

- 1.MATERIAL: THERMOPLASTIC UL94V-0
- 2.COLOR: BLACK OR GRAY (SEE PART NUMBER INFORMATION)
- 3.DIMENSIONS: INCHES [MM]
- 4.TOLERANCE: ±0.015 [0.381]

JACKET INSERT TREE

- 1.MATERIAL: POLYPROPYLENE HOMOPOLYMER
- 2.COLOR: BLACK
- 3.DIMENSIONS: INCHES [MM]
- 4.TOLERANCE: ±0.010 [0.254]

THIS IS A CONTROLLED DOCUMENT AND IS SUBJECT TO CHANGE. CONTACT NORTHERN TECHNOLOGIES ENGINEERING FOR THE LATEST REVISION.

UNLESS OTHERWISE SPECIFIED 1. ALL DIMENSIONS ARE IN INCHES (MM) 2. DIMENSIONS ARE TYPICAL		Northern Technologies <small>THIS DRAWING IS THE PROPERTY OF NORTHERN TECHNOLOGIES AND SHOULD NOT BE REPRODUCED WITHOUT NORTHERN TECHNOLOGIES WRITTEN PERMISSION.</small>		
DRAWN JSD 27-APR-05		PART NUMBER SEE PART NUMBER INFORMATION		
CHECKED SCN 27-APR-05		DESCRIPTION CPP 37 45 DEGREE EXIT TWO PIECE PLASTIC COVER		
ISSUED 01-SEP-05		SIZE B	CODE 200_130	DWG NO. 0002-200-130
SCALE 1:1		SHEET 1 OF 1		REV