

REVISIONS				
ZONE	REV	DESCRIPTION	DATE	APPROVED
	A	ECN 0607	10-AUG-06	
	B	ECN 0844	19-FEB-24	

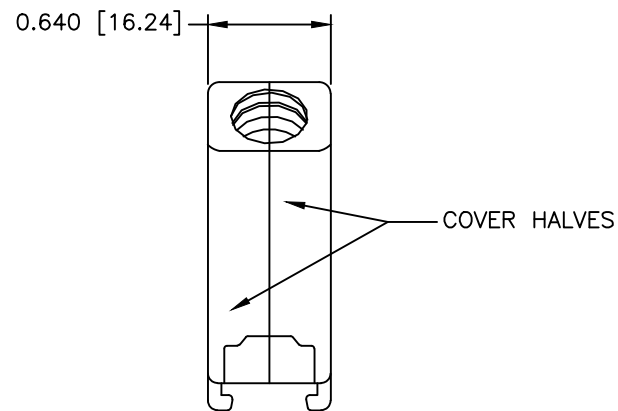
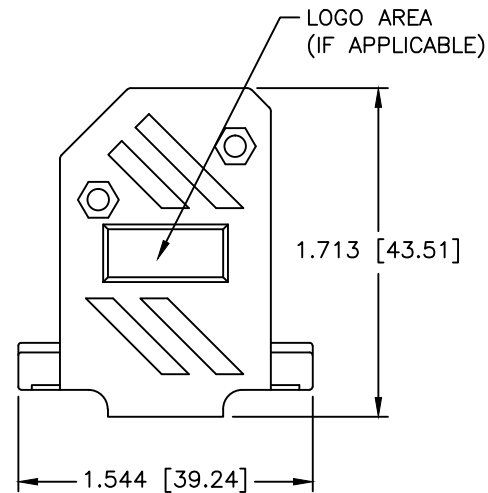
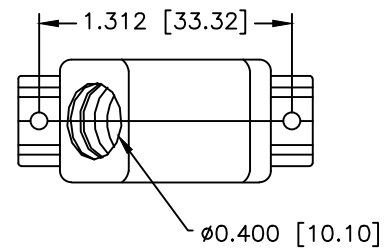

PART NUMBER INFORMATION

COLOR: BLACK

PART#	LOGO STYLE	SUPPLIED
A30E210004	NO LOGO	BULK
C88E210004	NO LOGO	PACKAGED
A30E211004	NORTECH LOGO*	BULK
C88E211004	NORTECH LOGO*	PACKAGED

COLOR: GRAY - DISCONTINUED

PART#	LOGO STYLE	SUPPLIED
A30E210005	NO LOGO	DISCONTINUED
C88E210005	NO LOGO	DISCONTINUED
A30E211005	NORTECH LOGO*	DISCONTINUED
C88E211005	NORTECH LOGO*	DISCONTINUED

* - SPECIAL ORDER ITEM - CONTACT NORTHERN TECHNOLOGIES

#4-40 X 7/16" FILLISTER HEAD MACHINE SCREW
MATERIAL - STEEL
FINISH - BRIGHT ZINC (HEXAVALENT CHROMIUM FREE)
QTY: 2 EACH

#4-40 #2 BLANK HEX NUT
MATERIAL - STEEL
FINISH - BRIGHT ZINC (HEXAVALENT CHROMIUM FREE)
QTY: 2 EACH

#4-40 X 1/2" FILLISTER HEAD CAPTIVE SCREW
MATERIAL - STEEL
FINISH - BRIGHT ZINC (HEXAVALENT CHROMIUM FREE)
QTY: 2 EACH

#4 SADDLE WASHER
MATERIAL - STEEL
FINISH - BRIGHT ZINC (HEXAVALENT CHROMIUM FREE)
QTY: 2 EACH

CONNECTOR COVER:

- 1.MATERIAL: THERMOPLASTIC UL94V-0
- 2.COLOR: BLACK
- 3.DIMENSIONS: INCHES [MM]
- 4.TOLERANCE: ±0.015 [0.381]

JACKET INSERT TREE

- 1.MATERIAL: POLYPROPYLENE HOMOPOLYMER
- 2.COLOR: BLACK
- 3.DIMENSIONS: INCHES [MM]
- 4.TOLERANCE: ±0.010 [0.254]

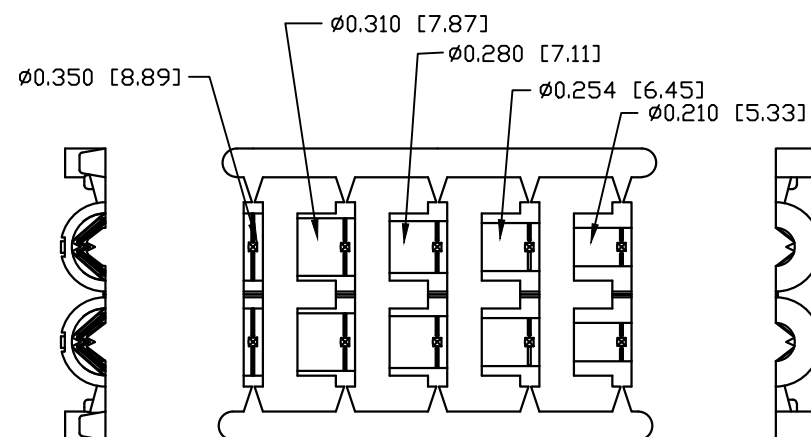

JACKET INSERT TREE
QTY: 1

THIS IS A CONTROLLED DOCUMENT AND IS SUBJECT TO CHANGE. CONTACT NORTHERN TECHNOLOGIES ENGINEERING FOR THE LATEST REVISION.

UNLESS OTHERWISE SPECIFIED 1. ALL DIMENSIONS ARE IN INCHES (MM) 2. DIMENSIONS ARE TYPICAL		Northern Technologies <small>THIS DRAWING IS THE PROPERTY OF NORTHERN TECHNOLOGIES AND SHOULD NOT BE REPRODUCED WITHOUT NORTHERN TECHNOLOGIES WRITTEN PERMISSION.</small>		
DRAWN JSD 27-APR-05		PART NUMBER SEE PART NUMBER INFORMATION		
CHECKED SCN 27-APR-05		DESCRIPTION CPP 15 45 DEGREE EXIT TWO PIECE PLASTIC COVER		
ISSUED 01-SEP-05		SIZE B	CODE 200_128	REV B
SCALE 1:1		DWG NO. 0002-200-128		SHEET 1 OF 1