

REVISIONS				
ZONE	REV	DESCRIPTION	DATE	APPROVED
	A	ECN 0733	06-NOV-13	
	B	ECN 0844	19-FEB-24	

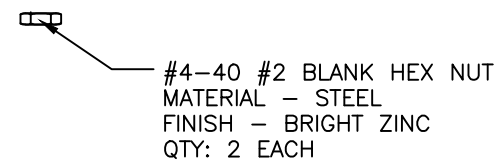

PART NUMBER INFORMATION  
COLOR: BLACK

PART#	LOGO STYLE	SUPPLIED
C88E200004T3	NO LOGO	PACKAGED
C88E201004T3	NORTECH LOGO	PACKAGED

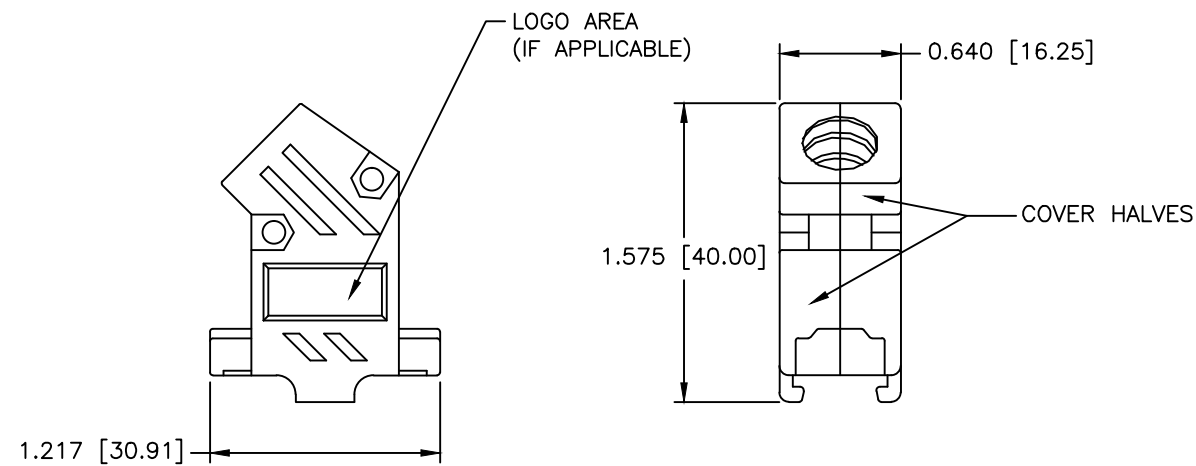
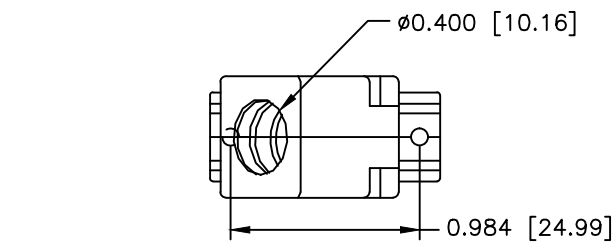
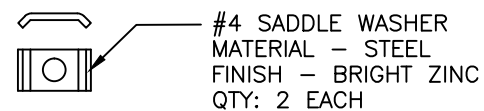

COLOR: GRAY - DISCONTINUED

PART#	LOGO STYLE	SUPPLIED
C88E200005T3	NO LOGO	DISCONTINUED
C88E201005T3	NORTECH LOGO*	DISCONTINUED

\* - SPECIAL ORDER ITEM - CONTACT NORTHERN TECHNOLOGIES

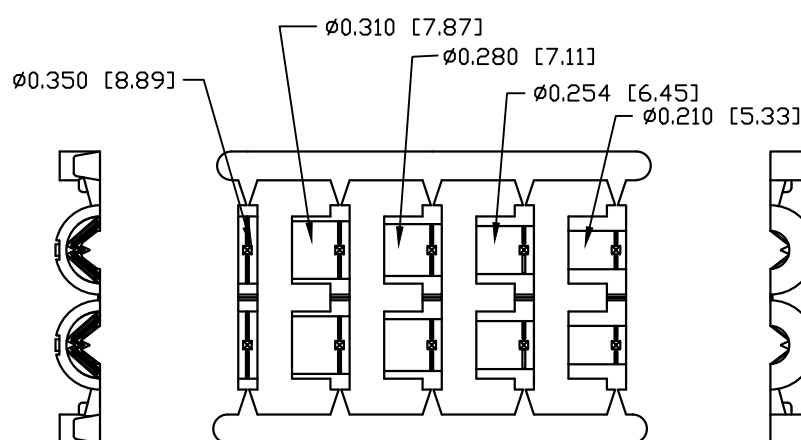

JACKET INSERT TREE  
QTY: 1

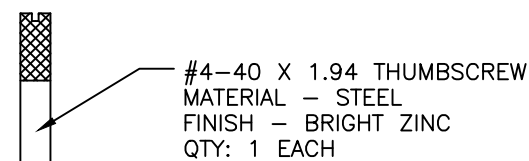

CONNECTOR COVER:

- 1.MATERIAL: THERMOPLASTIC UL94V-0
- 2.COLOR: BLACK
- 3.DIMENSIONS: INCHES [MM]
- 4.TOLERANCE: ±0.015 [0.381]

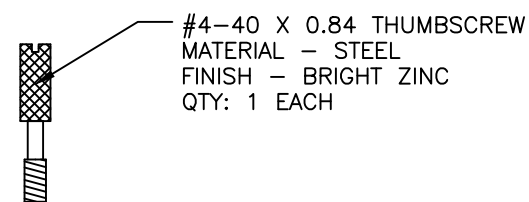

JACKET INSERT TREE

- 1.MATERIAL: POLYPROPYLENE HOMOPOLYMER
- 2.COLOR: BLACK
- 3.DIMENSIONS: INCHES [MM]
- 4.TOLERANCE: ±0.010 [0.254]

THIS IS A CONTROLLED DOCUMENT AND IS SUBJECT TO CHANGE. CONTACT NORTHERN TECHNOLOGIES ENGINEERING FOR THE LATEST REVISION.

UNLESS OTHERWISE SPECIFIED 1. ALL DIMENSIONS ARE IN INCHES (MM) 2. DIMENSIONS ARE TYPICAL		<b>Northern Technologies</b> THIS DRAWING IS THE PROPERTY OF NORTHERN TECHNOLOGIES AND SHOULD NOT BE REPRODUCED WITHOUT NORTHERN TECHNOLOGIES WRITTEN PERMISSION.		
DRAWN JSD		PART NUMBER SEE PART NUMBER INFORMATION		
09-DEC-08		DESCRIPTION CPP 09 45 DEGREE EXIT TWD PIECE PLASTIC COVER WITH THUMBSCREWS		
CHECKED SCN	09-DEC-08	SIZE B	CODE 200_127T3	DWG NO. 0002-200-127T3
ISSUED	09-DEC-08	SCALE N.T.S.		REV B
				SHEET 1 OF 1