

REVISIONS				
ZONE	REV	DESCRIPTION	DATE	APPROVED
	A	ECN 0607	10-AUG-06	
	B	ECN 0733	06-NOV-13	
	C	ECN 0844	19-FEB-24	

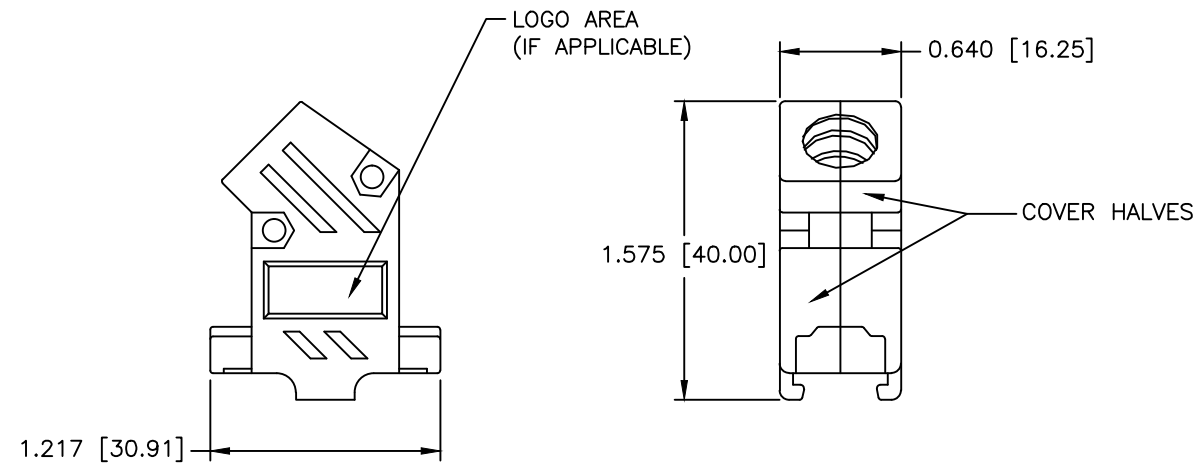
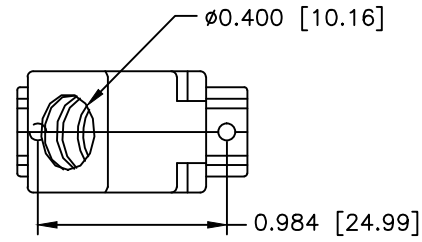

**PART NUMBER INFORMATION**  
COLOR: BLACK

PART#	LOGO STYLE	SUPPLIED
A30E200004	NO LOGO	BULK
C88E200004	NO LOGO	PACKAGED
A30E201004	NORTECH LOGO	BULK
C88E201004	NORTECH LOGO	PACKAGED

COLOR: GRAY - DISCONTINUED

PART#	LOGO STYLE	SUPPLIED
A30E200005	NO LOGO	DISCONTINUED
C88E200005	NO LOGO	DISCONTINUED
A30E201005	NORTECH LOGO*	DISCONTINUED
C88E201005	NORTECH LOGO*	DISCONTINUED

\* - SPECIAL ORDER ITEM - CONTACT NORTHERN TECHNOLOGIES

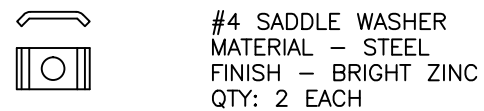
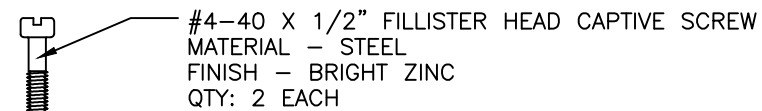
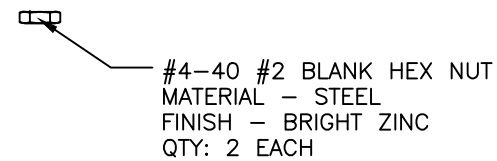

CONNECTOR COVER:

- 1.MATERIAL: THERMOPLASTIC UL94V-0
- 2.COLOR: BLACK
- 3.DIMENSIONS: INCHES [MM]
- 4.TOLERANCE: ±0.015 [0.381]

JACKET INSERT TREE

- 1.MATERIAL: POLYPROPYLENE HOMOPOLYMER
- 2.COLOR: BLACK
- 3.DIMENSIONS: INCHES [MM]
- 4.TOLERANCE: ±0.010 [0.254]

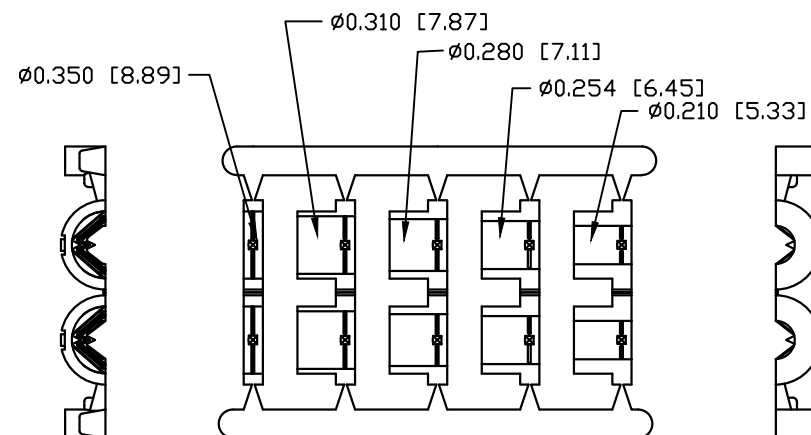

JACKET INSERT TREE  
QTY: 1

THIS IS A CONTROLLED DOCUMENT AND IS SUBJECT TO CHANGE. CONTACT NORTHERN TECHNOLOGIES ENGINEERING FOR THE LATEST REVISION.

UNLESS OTHERWISE SPECIFIED 1. ALL DIMENSIONS ARE IN INCHES (MM) 2. DIMENSIONS ARE TYPICAL		<b>Northern Technologies</b> <small>THIS DRAWING IS THE PROPERTY OF NORTHERN TECHNOLOGIES AND SHOULD NOT BE REPRODUCED WITHOUT NORTHERN TECHNOLOGIES WRITTEN PERMISSION.</small>		
DRAWN JSD 27-APR-05		PART NUMBER SEE PART NUMBER INFORMATION		
CHECKED SCN 27-APR-05		DESCRIPTION CPP 09 45 DEGREE EXIT TWO PIECE PLASTIC COVER		
ISSUED 01-SEP-05		SIZE B	CODE 200_127	DWG NO. 0002-200-127
		SCALE 1:1	SHEET 1 OF 1	