

BACK VIEW

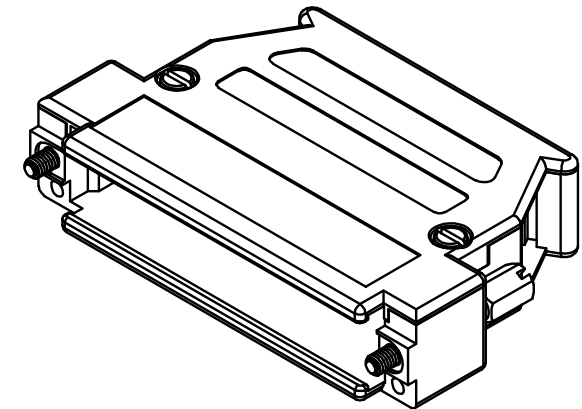

REVISIONS				
ZONE	REV	DESCRIPTION	DATE	APPROVED
	A	ECN0671	27-FEB-09	
	B	ECN0773A	09-JUN-15	

DISCONTINUED

PART NUMBER INFORMATION

PART#	THREAD	LOGO STYLE	SUPPLIED
MHDE3MK37KS	4-40	NO LOGO	PACKAGED
MHDE3MK37M3K	M3	NO LOGO	PACKAGED

CONNECTOR COVER:

- 1.MATERIAL: PLATING GRADE ABS
- 2.FINISH: NICKEL OVER COPPER UNDER-PLATE
- 3.DIMENSIONS: INCHES [MM]
- 4.TOLERANCE: ±0.015 [0.381]

THREAD TYPE — SEE PART NUMBER INFORMATION
 LOW CARBON STEEL
 FINISH: ZINC PLATE
 QTY: 2 EACH

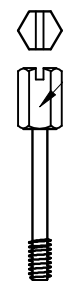

QTY: 1
 CABLE CLAMP — CR STEEL,
 FINISH: ZINC PLATE



BLANKING PLATES — CR STEEL,
 FINISH: ZINC PLATE
 QTY: 2 EACH

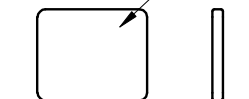

ASSEMBLY SCREWS — CR STEEL,
 FINISH: ZINC PLATE
 QTY: 4 EACH



UNLESS OTHERWISE SPECIFIED 1. ALL DIMENSIONS ARE IN INCHES (MM) 2. DIMENSIONS ARE TYPICAL		Northern Technologies <small>THIS DRAWING IS THE PROPERTY OF NORTHERN TECHNOLOGIES AND SHOULD NOT BE REPRODUCED WITHOUT NORTHERN TECHNOLOGIES' WRITTEN PERMISSION.</small>		
DRAWN Luis C. 16-JUL-08		PART NUMBER SEE PART NUMBER INFORMATION DESCRIPTION CMP3 37 3 WAY EXIT METALIZED PLASTIC COVER		
CHECKED JSD 16-JUL-08	ISSUED 25-JUL-08	SIZE B	CODE 200_121	DWG NO. 0002-200-121
		SCALE N.T.S.	SHEET 1 OF 1	