

REVISIONS				
ZONE	REV	DESCRIPTION	DATE	APPROVED
	A	ECN 0787	10-JUN-16	
	B	ECN 0816	17-AUG-20	

DISCONTINUED

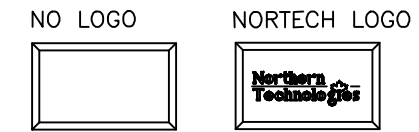
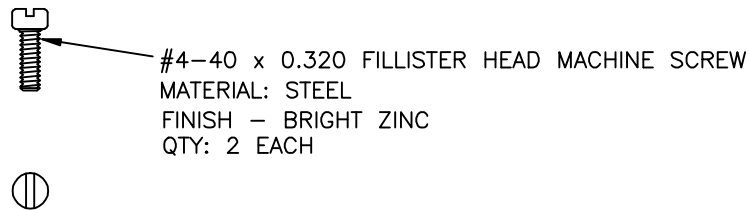
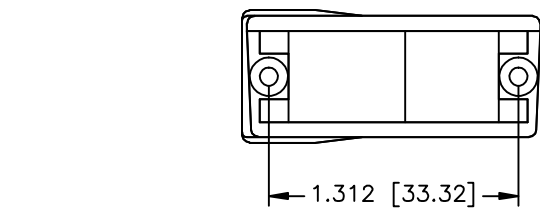
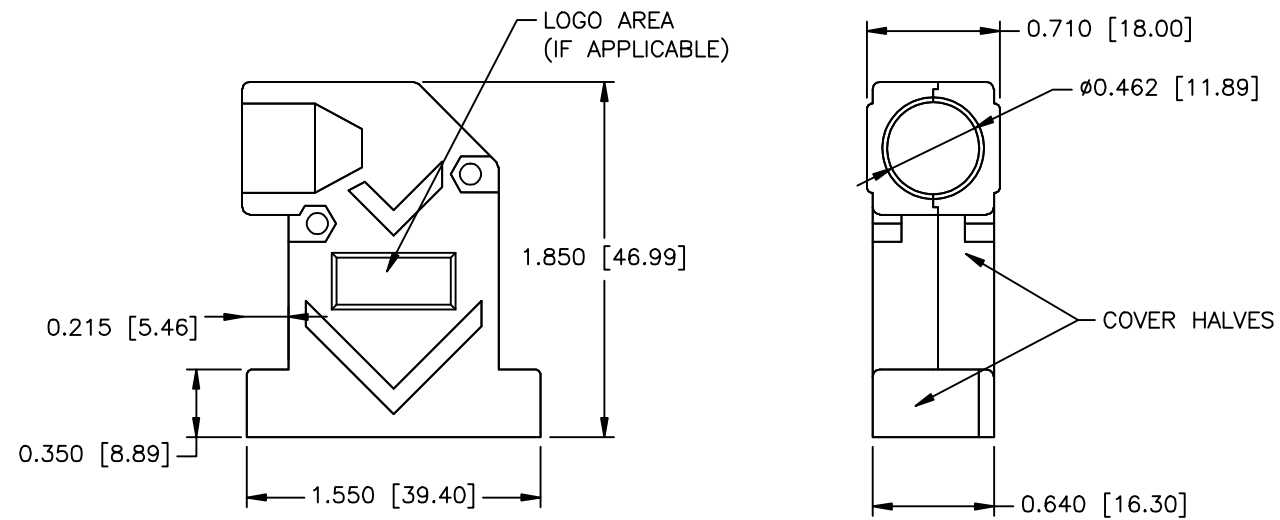

PART NUMBER INFORMATION

PART#	LOGO STYLE	SUPPLIED
N30E610002	NO LOGO	BULK
N88E610002	NO LOGO	PACKAGED
N30E611002	NORTECH LOGO*	BULK
N88E611002	NORTECH LOGO*	PACKAGED

*CONTACT NORTHERN TECHNOLOGIES

CONNECTOR COVER:

- 1.MATERIAL: ZINC ALLOY
- 2.FINISH: NICKEL OVER COPPER UNDER-PLATE PER NTC SPECIFICATION N/T 000400
- 3.DIMENSIONS: INCHES [MM]
- 4.TOLERANCE: ± 0.015 [0.381]

COMPRESSION INSERT TREE

- 1.MATERIAL: THERMOPLASTIC
- 2.COLOR: BLACK
- 3.DUROMETER: 75 ± 5 TYPE A PER ASTM D2240
- 4.DIMENSIONS: INCHES [MM]
- 5.TOLERANCE: ± 0.020 [0.508]

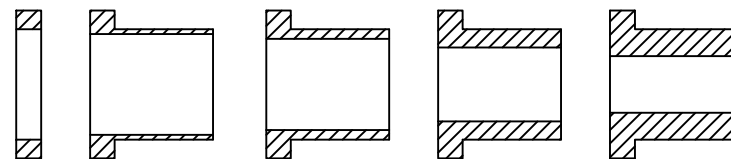
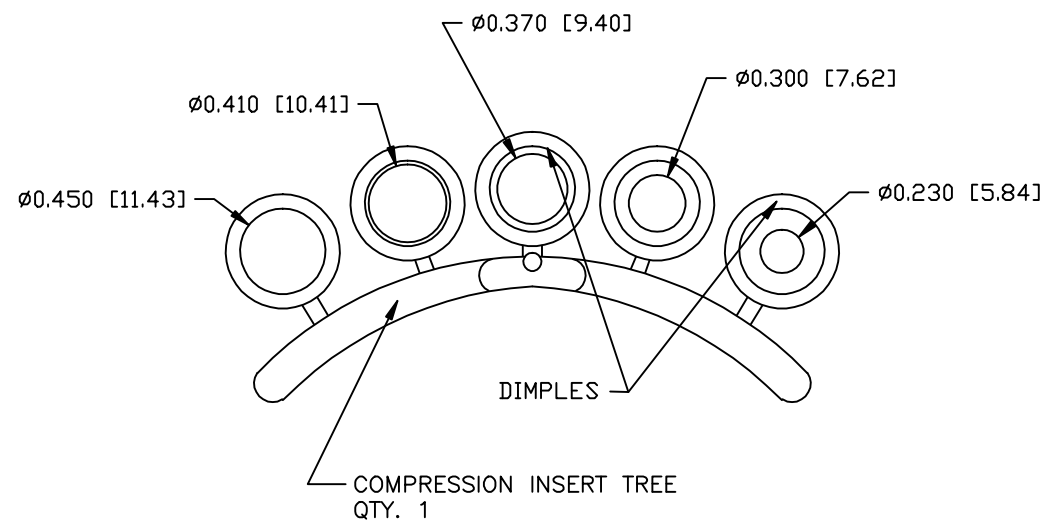

THIS IS A CONTROLLED DOCUMENT AND IS SUBJECT TO CHANGE. CONTACT NORTHERN TECHNOLOGIES ENGINEERING FOR THE LATEST REVISION.

UNLESS OTHERWISE SPECIFIED		Northern Technologies		
1. ALL DIMENSIONS ARE IN INCHES (MM) 2. DIMENSIONS ARE TYPICAL		THIS DRAWING IS THE PROPERTY OF NORTHERN TECHNOLOGIES AND SHOULD NOT BE REPRODUCED WITHOUT NORTHERN TECHNOLOGIES WRITTEN PERMISSION.		
DRAWN JSD 02-JAN-13		PART NUMBER SEE PART NUMBER INFORMATION		
CHECKED SCN 02-JAN-13		DESCRIPTION CME ETHERNET 15 RIGHT ANGLE METAL COVER		
ISSUED 02-JAN-13		SIZE B	CODE 200_111N	DWG NO. 0002-200-111N
		SCALE 1:1		REV
				SHEET 1 OF 1