

REVISIONS				
ZONE	REV	DESCRIPTION	DATE	APPROVED
	A	ECN 0787	10-JUN-16	

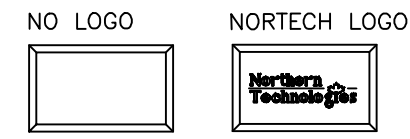
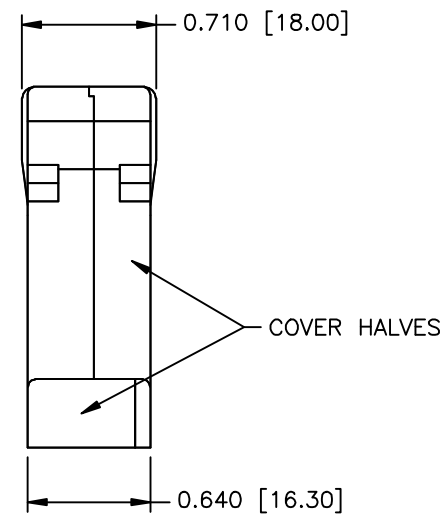
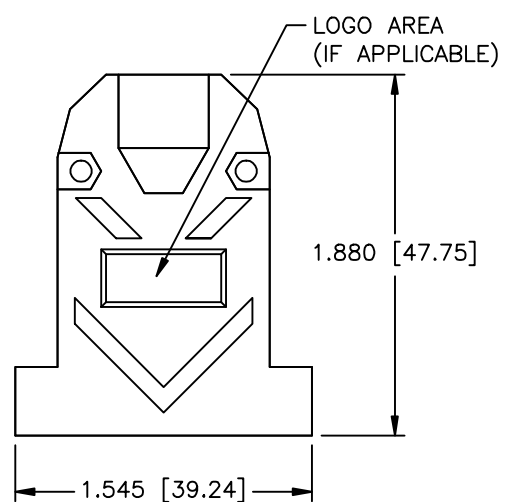
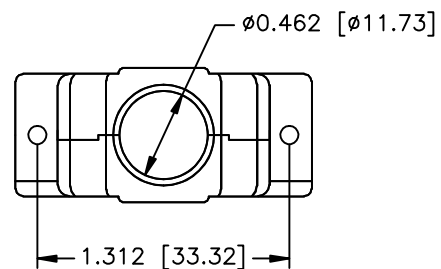

PART NUMBER INFORMATION

PART#	LOGO STYLE	SUPPLIED
N30E610001	NO LOGO	BULK
N88E610001	NO LOGO	PACKAGED
N30E611001	NORTECH LOGO*	BULK
N88E611001	NORTECH LOGO*	PACKAGED

*CONTACT NORTHERN TECHNOLOGIES

CONNECTOR COVER:

- 1.MATERIAL: ZINC ALLOY
- 2.FINISH: NICKEL OVER COPPER UNDER-PLATE PER NTC SPECIFICATION N/T 000400
- 3.DIMENSIONS: INCHES [MM]
- 4.TOLERANCE: ±0.015 [0.381]

COMPRESSION INSERT TREE

- 1.MATERIAL: THERMOPLASTIC
- 2.COLOR: BLACK
- 3.DUROMETER: 75 ±5 TYPE A PER ASTM D2240
- 4.DIMENSIONS: INCHES [MM]
- 5.TOLERANCE: ±0.020 [0.508]

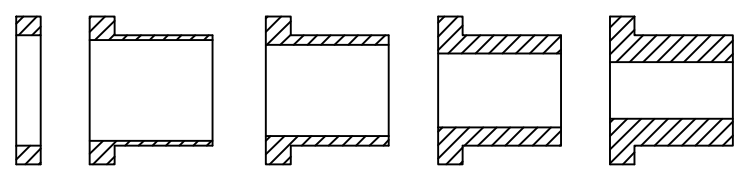
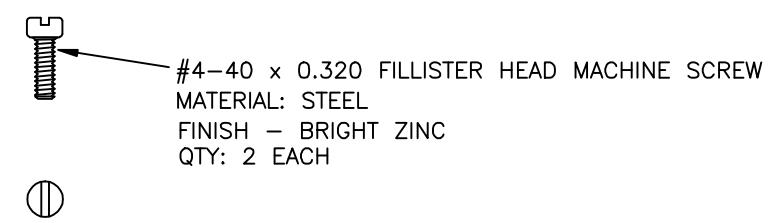
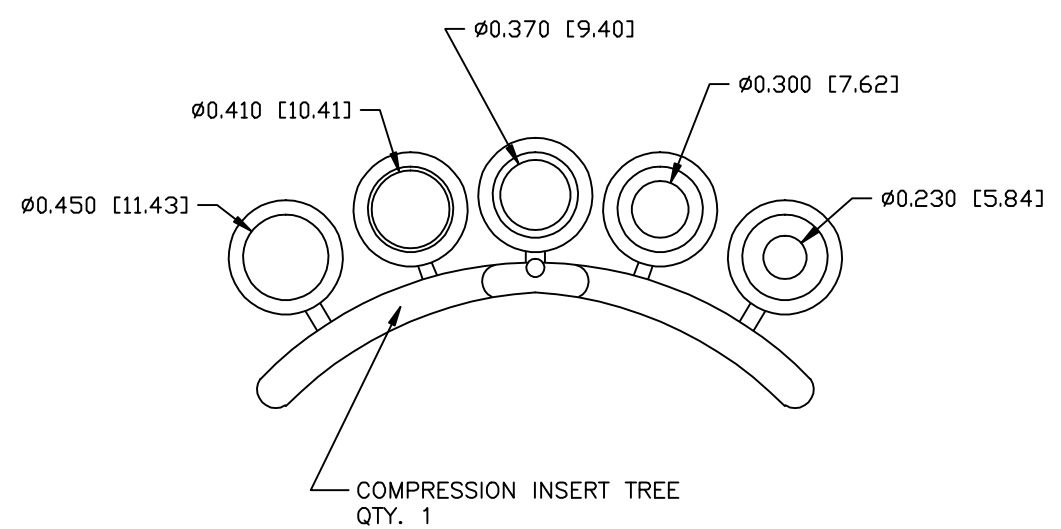

THIS IS A CONTROLLED DOCUMENT AND IS SUBJECT TO CHANGE. CONTACT NORTHERN TECHNOLOGIES ENGINEERING FOR THE LATEST REVISION.

UNLESS OTHERWISE SPECIFIED		Northern Technologies <small>THIS DRAWING IS THE PROPERTY OF NORTHERN TECHNOLOGIES AND SHOULD NOT BE REPRODUCED WITHOUT NORTHERN TECHNOLOGIES WRITTEN PERMISSION.</small>		
<small>1. ALL DIMENSIONS ARE IN INCHES (MM) 2. DIMENSIONS ARE TYPICAL</small>		PART NUMBER SEE PART NUMBER INFORMATION DESCRIPTION CME ETHERNET 15 METAL COVER (LONG)		
DRAWN	JSD 02-JAN-13	SIZE B	CODE 200_110N	REV
CHECKED	SCN 02-JAN-13	DWG NO.	0002-200-110N	
ISSUED	02-JAN-13	SCALE 1:1		SHEET 1 OF 1