

REVISIONS

ZONE	REV	DESCRIPTION	DATE	APPROVED

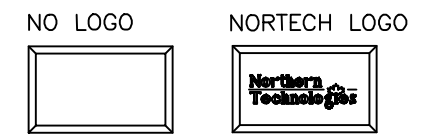

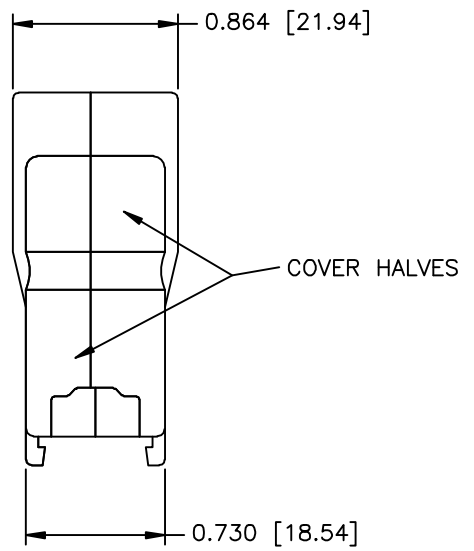
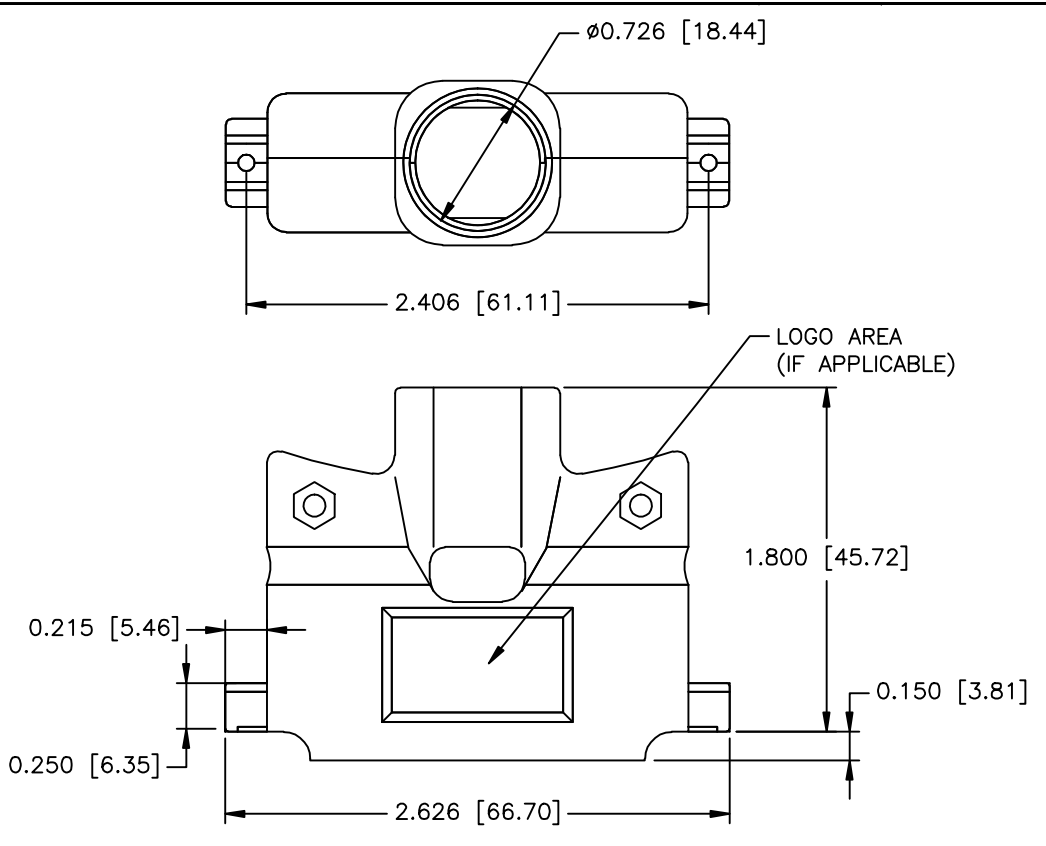

PART NUMBER INFORMATION

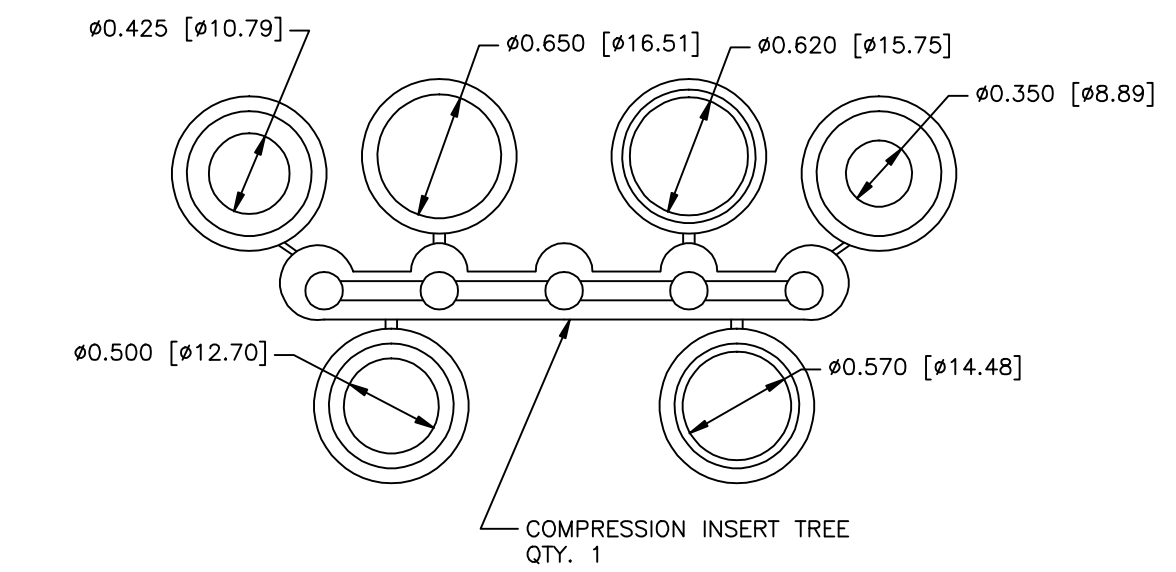
PART#	LOGO STYLE	SUPPLIED
C88E000212T	NO LOGO	PACKAGED
C88E000208T	NORTECH LOGO	PACKAGED



COMPRESSION INSERT TREE  
QTY. 1

 #4-40 X 7/16" FILLISTER HEAD MACHINE SCREW  
MATERIAL - STEEL  
FINISH - BRIGHT ZINC (HEXAVALENT CHROMIUM FREE)  
QTY: 2 EACH

 #4-40 #2 BLANK HEX NUT  
MATERIAL - STEEL  
FINISH - BRIGHT ZINC (HEXAVALENT CHROMIUM FREE)  
QTY: 2 EACH

 #4 SADDLE WASHER  
MATERIAL - STEEL  
FINISH - BRIGHT ZINC (HEXAVALENT CHROMIUM FREE)  
QTY: 2 EACH

 #4-40 X 1.94 THUMBSCREW  
MATERIAL - STEEL  
FINISH - BRIGHT ZINC (HEXAVALENT CHROMIUM FREE)  
QTY: 2 EACH

CONNECTOR COVER:

- 1.MATERIAL: ZINC ALLOY
- 2.FINISH: BRIGHT ZINC PLATING PER NTC SPECIFICATION N/T 000100
- 3.DIMENSIONS: INCHES [MM]
- 4.TOLERANCE: ±0.015 [0.381]

COMPRESSION INSERT TREE

- 1.MATERIAL: THERMOPLASTIC
- 2.COLOR: BLACK
- 3.DUROMETER: 75 ±5 TYPE A PER ASTM D2240
- 4.DIMENSIONS: INCHES [MM]
- 5.TOLERANCE: ±0.020 [0.508]

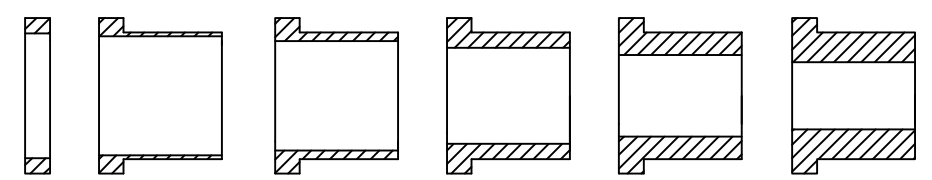

THIS IS A CONTROLLED DOCUMENT AND IS SUBJECT TO CHANGE. CONTACT NORTHERN TECHNOLOGIES ENGINEERING FOR THE LATEST REVISION.

UNLESS OTHERWISE SPECIFIED 1. ALL DIMENSIONS ARE IN INCHES (MM) 2. DIMENSIONS ARE TYPICAL		<b>Northern Technologies</b> <small>THIS DRAWING IS THE PROPERTY OF NORTHERN TECHNOLOGIES AND SHOULD NOT BE REPRODUCED WITHOUT NORTHERN TECHNOLOGIES' WRITTEN PERMISSION.</small>			
DRAWN JSD 23-JAN-07					PART NUMBER SEE PART NUMBER INFORMATION
CHECKED SCN 23-JAN-07		DESCRIPTION CM 50 METAL COVER WITH THUMBSCREWS			
ISSUED 23-JAN-07		SIZE B	CODE 200_105T	DWG NO. 0002-200-105T	REV
SCALE 1:1		SHEET 1 OF 1			