

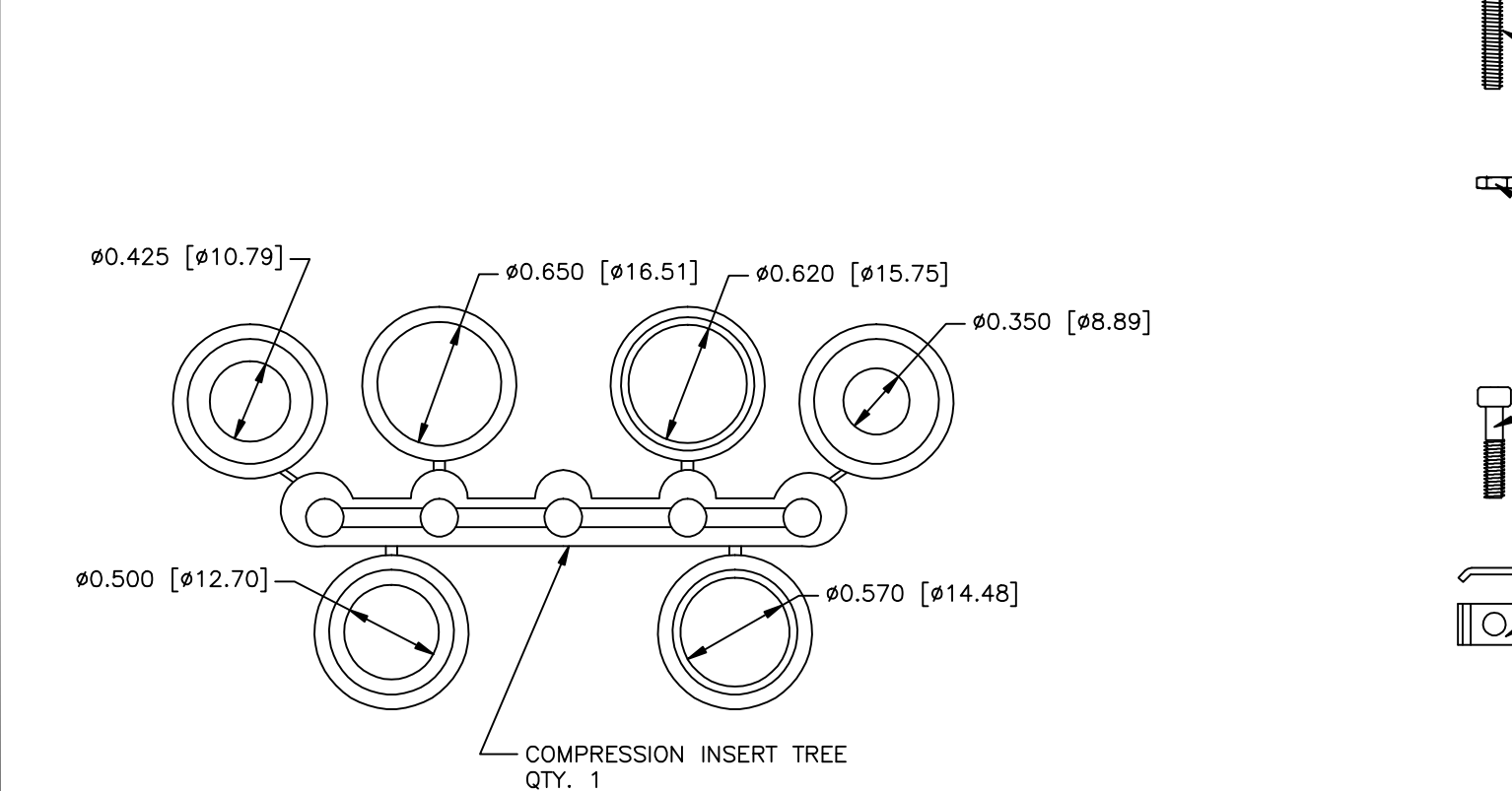

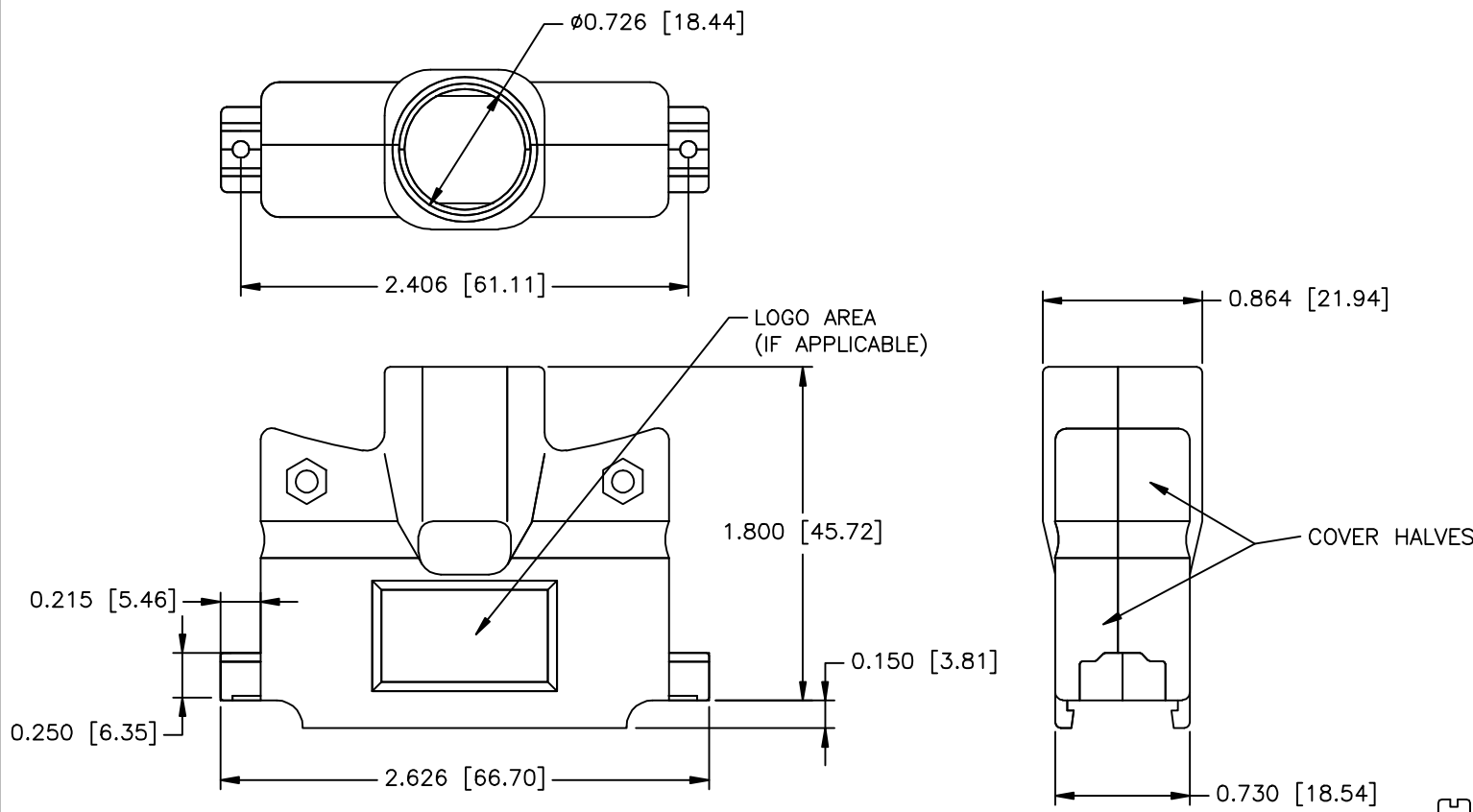

REVISIONS

ZONE	REV	DESCRIPTION	DATE	APPROVED



-  #4-40 X 7/16" FILLISTER HEAD MACHINE SCREW
MATERIAL - STEEL
FINISH - BRIGHT ZINC
QTY: 2 EACH
-  #4-40 #2 BLANK HEX NUT
MATERIAL - STEEL
FINISH - BRIGHT ZINC
QTY: 2 EACH
-  FILLISTER HEAD CAPTIVE SCREW
HEAD STYLE - SEE PAGE 2
MATERIAL - SEE PAGE 2
FINISH - SEE PAGE 2
QTY: 2 EACH
-  #4 SADDLE WASHER
MATERIAL - STEEL
FINISH - BRIGHT ZINC
QTY: 2 EACH

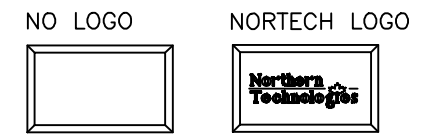

CONNECTOR COVER:
 1.MATERIAL: ZINC ALLOY
 2.FINISH: NICKEL PLATING PER NTC SPECIFICATION N/T 000400
 3.DIMENSIONS: INCHES [MM]
 4.TOLERANCE: ±0.015 [0.381]

COMPRESSION INSERT TREE
 1.MATERIAL: THERMOPLASTIC
 2.COLOR: BLACK
 3.DUROMETER: 75 ±5 TYPE A PER ASTM D2240
 4.DIMENSIONS: INCHES [MM]
 5.TOLERANCE: ±0.020 [0.508]

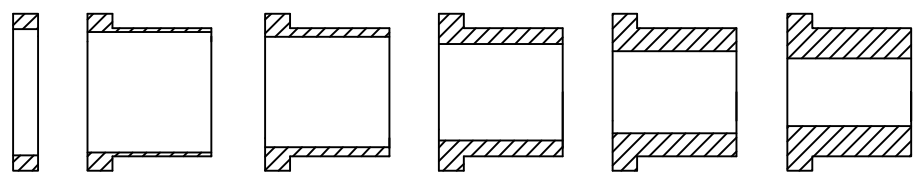

THIS IS A CONTROLLED DOCUMENT AND IS SUBJECT TO CHANGE. CONTACT NORTHERN TECHNOLOGIES ENGINEERING FOR THE LATEST REVISION.

UNLESS OTHERWISE SPECIFIED 1. ALL DIMENSIONS ARE IN INCHES (MM) 2. DIMENSIONS ARE TYPICAL		Northern Technologies <small>THIS DRAWING IS THE PROPERTY OF NORTHERN TECHNOLOGIES AND SHOULD NOT BE REPRODUCED WITHOUT NORTHERN TECHNOLOGIES WRITTEN PERMISSION.</small>		
DRAWN JSD 29-JUL-13		PART NUMBER SEE PART NUMBER INFORMATION DESCRIPTION CM 50 METAL COVER Ni		
CHECKED SCN 29-JUL-13	ISSUED 29-JUL-13	SIZE B	CODE 200_105N	DWG NO. 0002-200-105N
		SCALE NTS	SHEET 1 OF 2	

PART NUMBER INFORMATION

PART#	WITH #4-40 X 1/2" CAPTIVE SCREWS (SLOT HEAD)	SUPPLIED
N29E821503	NO LOGO COVER TOP	BULK
N29E921500	NORTECH LOGO COVER TOP	BULK
N30E140100	COVER BOTTOM	BULK
N88E000212	NO LOGO	PACKAGED
N88E000208	NORTECH LOGO	PACKAGED

PART#	WITH #4-40 X 7/16" CAPTIVE SCREWS (SLOT HEAD)	SUPPLIED
N29E8215031	NO LOGO COVER TOP	BULK
N29E9215001	NORTECH LOGO COVER TOP	BULK
N30E140100	COVER BOTTOM	BULK
N88E0002121	NO LOGO	PACKAGED
N88E0002081	NORTECH LOGO	PACKAGED

PART#	WITH M2.5 X 12.7MM CAPTIVE SCREWS (SLOT HEAD)	SUPPLIED
N29E821503M25S	NO LOGO COVER TOP	BULK
N29E921500M25S	NORTECH LOGO COVER TOP	BULK
N30E140100	COVER BOTTOM	BULK
N88E000212M25S	NO LOGO	PACKAGED
N88E000208M25S	NORTECH LOGO	PACKAGED

PART#	WITH M2.6 X 12.7MM CAPTIVE SCREWS (SLOT HEAD)	SUPPLIED
N29E821503M26S	NO LOGO COVER TOP	BULK
N29E921500M26S	NORTECH LOGO COVER TOP	BULK
N30E140100	COVER BOTTOM	BULK
N88E000212M26S	NO LOGO	PACKAGED
N88E000208M26S	NORTECH LOGO	PACKAGED

PART#	WITH M3 X 12.7MM CAPTIVE SCREWS (SLOT HEAD)	SUPPLIED
N29E821503M3S	NO LOGO COVER TOP	BULK
N29E921500M3S	NORTECH LOGO COVER TOP	BULK
N30E140100	COVER BOTTOM	BULK
N88E000212M3S	NO LOGO	PACKAGED
N88E000208M3S	NORTECH LOGO	PACKAGED

PART#	WITH #4-40 X 1/2" CAPTIVE SCREWS (PHILLIPS HEAD)	SUPPLIED
N29E821503PS	NO LOGO COVER TOP	BULK
N29E921500PS	NORTECH LOGO COVER TOP	BULK
N30E140100	COVER BOTTOM	BULK
N88E000212PS	NO LOGO	PACKAGED
N88E000208PS	NORTECH LOGO	PACKAGED

REVISIONS				
ZONE	REV	DESCRIPTION	DATE	APPROVED

FILLISTER HEAD CAPTIVE SCREW

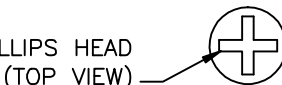
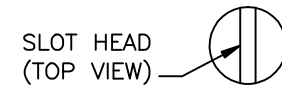
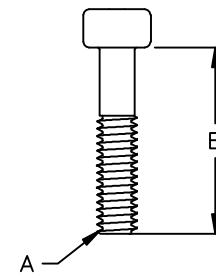

THREAD (A)	LENGTH (B)	HEAD STYLE	MATERIAL	PLATING
#4-40 UNC	1/2 INCH	SLOT	COLD ROLL STEEL	ZINC
#4-40 UNC	7/16 INCH	SLOT	COLD ROLL STEEL	ZINC
M2.5 X .45MM	12.7 MM	SLOT	LOW CARBON STEEL	ZINC
M2.6 X .45MM	12.7 MM	SLOT	LOW CARBON STEEL	ZINC
M3 X .5MM	12.7 MM	SLOT	LOW CARBON STEEL	ZINC
#4-40 UNC	1/2 INCH	PHILLIPS	LOW CARBON STEEL	ZINC

THIS IS A CONTROLLED DOCUMENT AND IS SUBJECT TO CHANGE. CONTACT NORTHERN TECHNOLOGIES ENGINEERING FOR THE LATEST REVISION.

UNLESS OTHERWISE SPECIFIED 1. ALL DIMENSIONS ARE IN INCHES [MM] 2. DIMENSIONS ARE TYPICAL		Northern Technologies <small>THIS DRAWING IS THE PROPERTY OF NORTHERN TECHNOLOGIES AND SHOULD NOT BE REPRODUCED WITHOUT NORTHERN TECHNOLOGIES WRITTEN PERMISSION.</small>		
DRAWN JSD		PART NUMBER SEE PART NUMBER INFORMATION DESCRIPTION CM 50 METAL COVER Ni		
CHECKED SCN	29-JUL-13	SIZE B	CODE 200_105N	DWG NO. 0002-200-105N
ISSUED	29-JUL-13	SCALE NTS	SHEET 2 OF 2	