

REVISIONS				
ZONE	REV	DESCRIPTION	DATE	APPROVED
	A	ECN 0755	12-NOV-14	

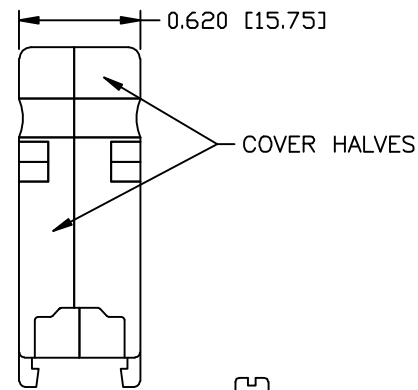

NO LOGO

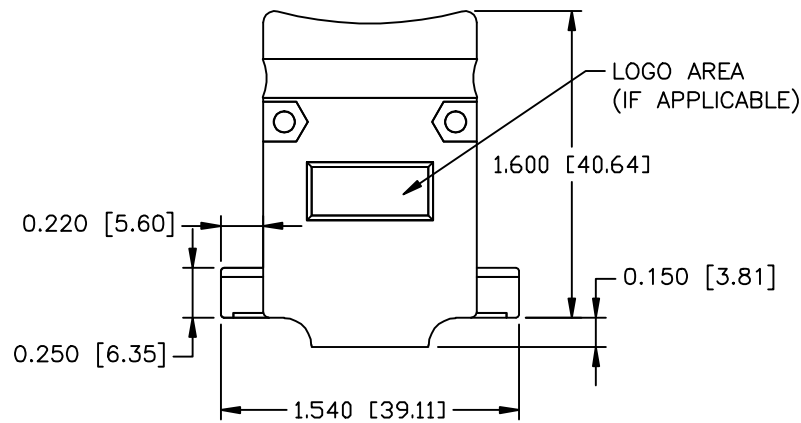
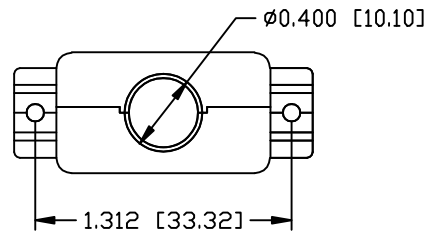
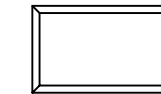

NORTECH LOGO



PART NUMBER INFORMATION

PART#	LOGO STYLE	SUPPLIED
C88E000211T	NO LOGO	PACKAGED
C88E000207T	NORTECH LOGO	PACKAGED

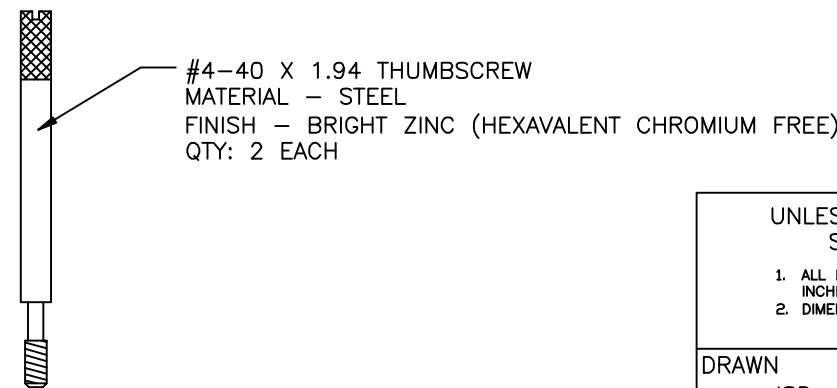
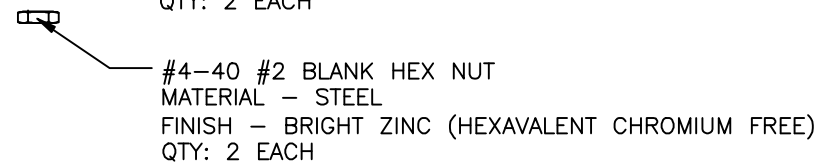
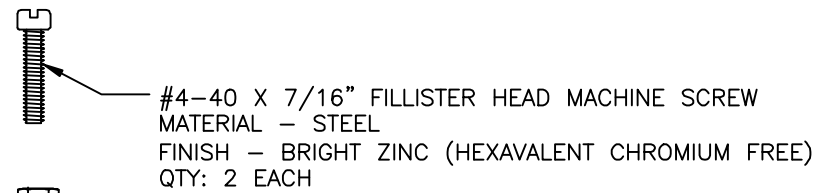
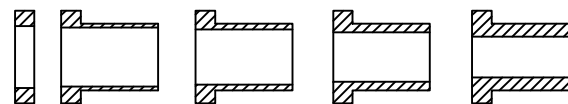
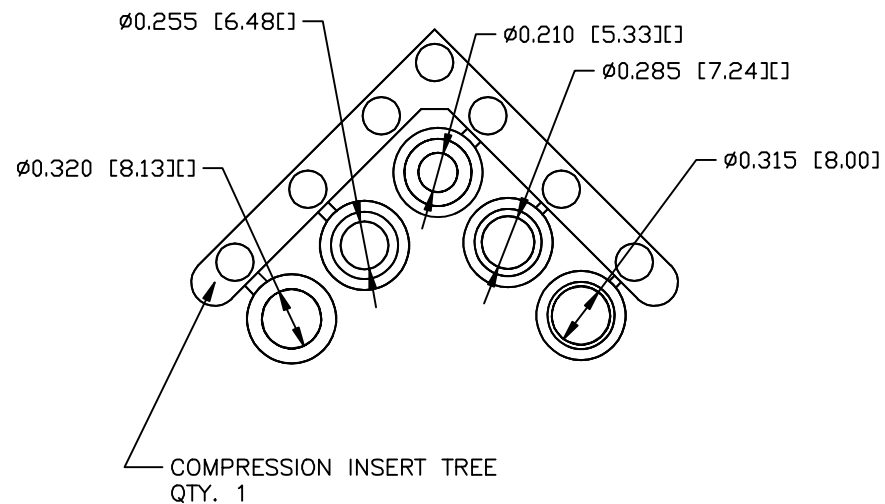

CONNECTOR COVER:

- 1.MATERIAL: ZINC ALLOY
- 2.FINISH: BRIGHT ZINC PLATING PER NTC SPECIFICATION N/T 000100
- 3.DIMENSIONS: INCHES [MM]
- 4.TOLERANCE: ±0.015 [0.381]

COMPRESSION INSERT TREE

- 1.MATERIAL: THERMOPLASTIC
- 2.COLOR: BLACK
- 3.DUROMETER: 75 ±5 TYPE A PER ASTM D2240
- 4.DIMENSIONS: INCHES [MM]
- 5.TOLERANCE: ±0.020 [0.508]

THIS IS A CONTROLLED DOCUMENT AND IS SUBJECT TO CHANGE. CONTACT NORTHERN TECHNOLOGIES ENGINEERING FOR THE LATEST REVISION.

UNLESS OTHERWISE SPECIFIED 1. ALL DIMENSIONS ARE IN INCHES (MM) 2. DIMENSIONS ARE TYPICAL		Northern Technologies THIS DRAWING IS THE PROPERTY OF NORTHERN TECHNOLOGIES AND SHOULD NOT BE REPRODUCED WITHOUT NORTHERN TECHNOLOGIES WRITTEN PERMISSION.		
DRAWN JSD 23-JAN-07		PART NUMBER SEE PART NUMBER INFORMATION DESCRIPTION CM 15 METAL COVER WITH THUMBSCREWS		
CHECKED SCN 23-JAN-07	ISSUED 23-JAN-07	SIZE B	CODE 200_102T	DWG NO. 0002-200-102T
		SCALE 1:1	SHEET 1 OF 1	