

REVISIONS				
ZONE	REV	DESCRIPTION	DATE	APPROVED
	A	ECN 0755	12-NOV-14	

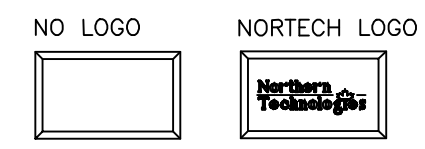

**PART NUMBER INFORMATION**

PART#	LOGO STYLE	SUPPLIED
C88E000209T	NO LOGO	PACKAGED
C88E000218T	NORTECH LOGO	PACKAGED

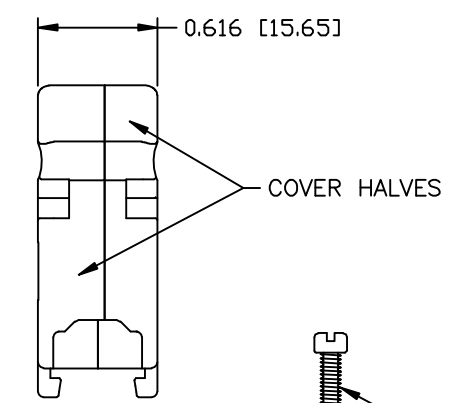
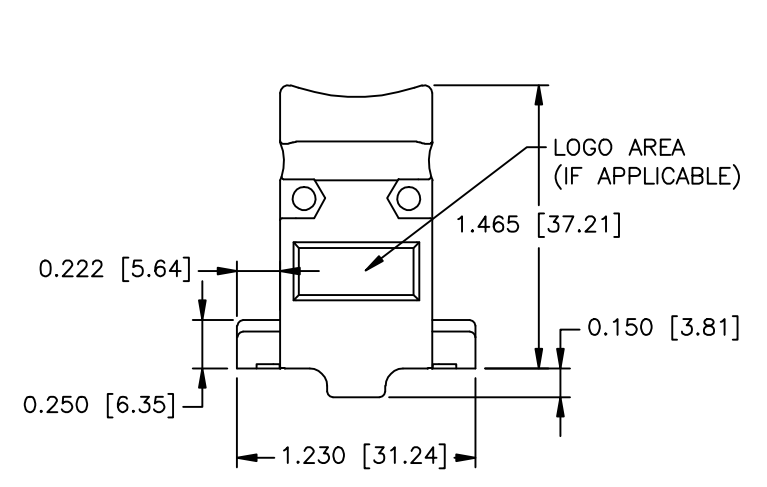
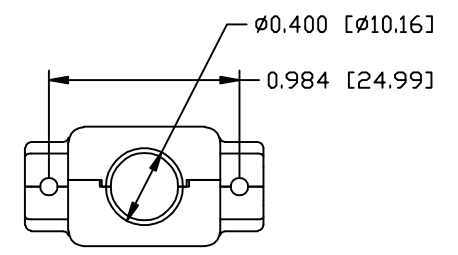
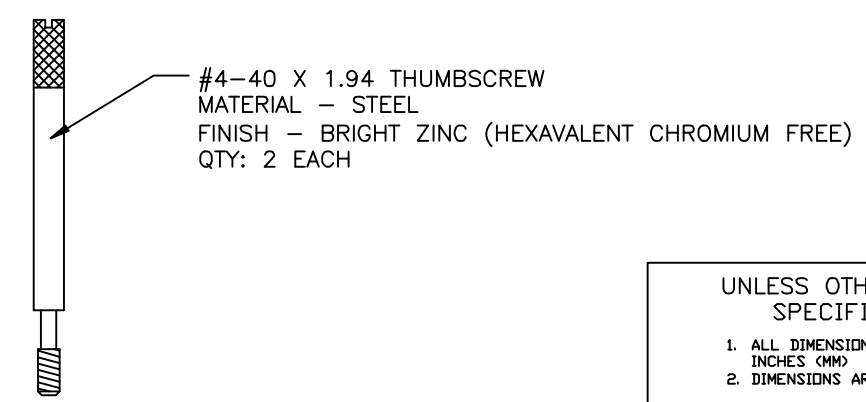
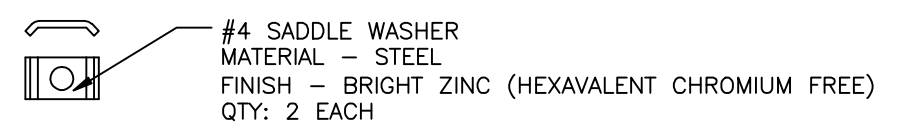
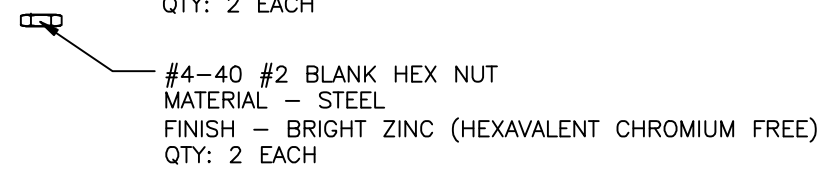
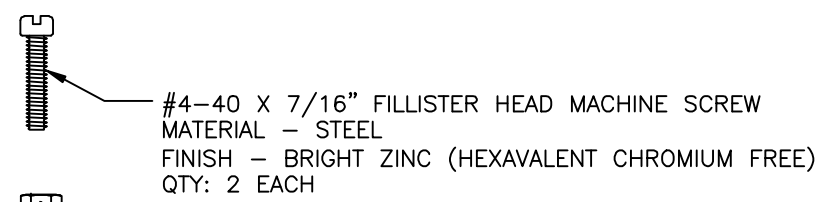
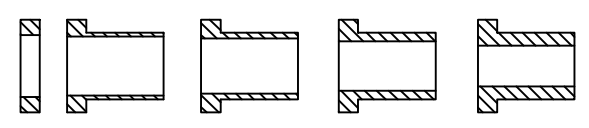
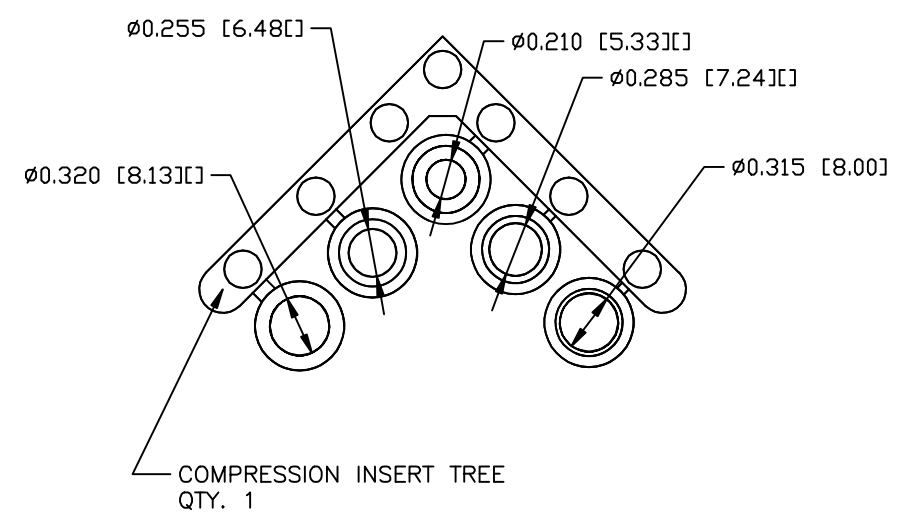

**CONNECTOR COVER:**

- 1.MATERIAL: ZINC ALLOY
- 2.FINISH: BRIGHT ZINC PLATING PER NTC SPECIFICATION N/T 000100
- 3.DIMENSIONS: INCHES [MM]
- 4.TOLERANCE: ±0.015 [0.381]

**COMPRESSION INSERT TREE**

- 1.MATERIAL: THERMOPLASTIC
- 2.COLOR: BLACK
- 3.DUROMETER: 75 ±5 TYPE A PER ASTM D2240
- 4.DIMENSIONS: INCHES [MM]
- 5.TOLERANCE: ±0.020 [0.508]

THIS IS A CONTROLLED DOCUMENT AND IS SUBJECT TO CHANGE. CONTACT NORTHERN TECHNOLOGIES ENGINEERING FOR THE LATEST REVISION.

UNLESS OTHERWISE SPECIFIED 1. ALL DIMENSIONS ARE IN INCHES (MM) 2. DIMENSIONS ARE TYPICAL		<b>Northern Technologies</b> <small>THIS DRAWING IS THE PROPERTY OF NORTHERN TECHNOLOGIES AND SHOULD NOT BE REPRODUCED WITHOUT NORTHERN TECHNOLOGIES WRITTEN PERMISSION.</small>		
DRAWN JSD 23-JAN-07		PART NUMBER SEE PART NUMBER INFORMATION		
CHECKED SCN 23-JAN-07		DESCRIPTION CM 09 METAL COVER WITH THUMBSCREWS		
ISSUED 23-JAN-07	SIZE B	CODE 200_101T	DWG NO. 0002-200-101T	REV
SCALE 1:1		SHEET 1 OF 1		