

REVISIONS				
ZONE	REV	DESCRIPTION	DATE	APPROVED
	A	ECN 0531	06-MAY-05	
	B	ECN 0600	10-AUG-06	
	C	ECN 0628	24-JAN-07	
	D	ECN 0643	24-JAN-08	
	E	ECN 0644	08-FEB-08	
	F	ECN 0755	12-NOV-14	

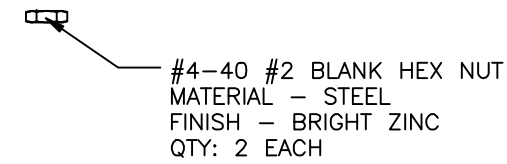

CONNECTOR COVER:

- 1.MATERIAL: ZINC ALLOY
- 2.FINISH: BRIGHT ZINC PLATING PER NTC SPECIFICATION N/T 000100
- 3.DIMENSIONS: INCHES [MM]
- 4.TOLERANCE: ±0.015 [0.381]

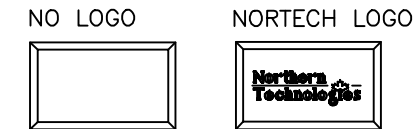
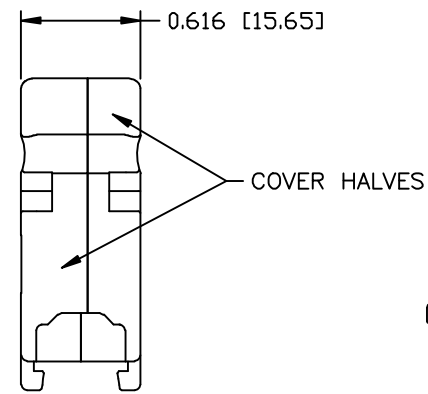
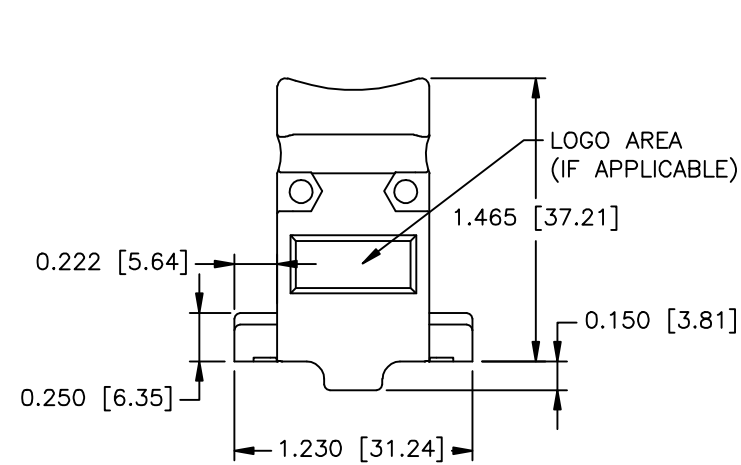
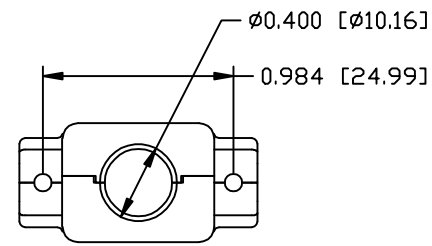
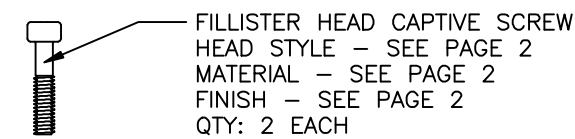

COMPRESSION INSERT TREE

- 1.MATERIAL: THERMOPLASTIC
- 2.COLOR: BLACK
- 3.DUROMETER: 75 ±5 TYPE A PER ASTM D2240
- 4.DIMENSIONS: INCHES [MM]
- 5.TOLERANCE: ±0.020 [0.508]

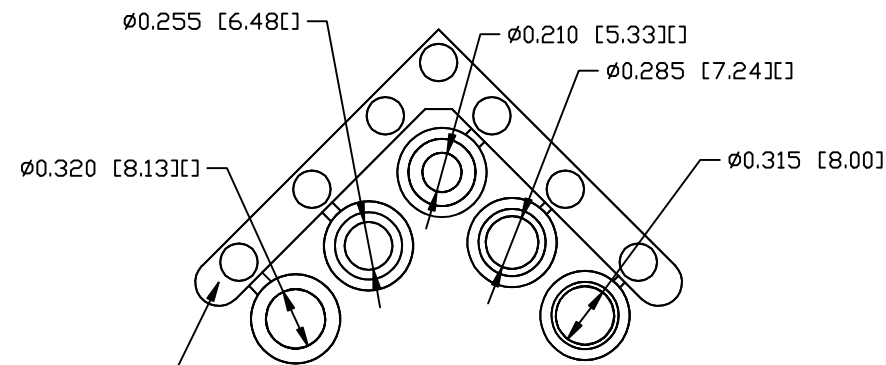
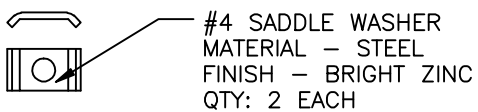

COMPRESSION INSERT TREE  
QTY. 1

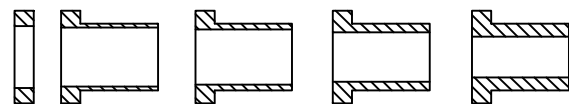

UNLESS OTHERWISE SPECIFIED 1. ALL DIMENSIONS ARE IN INCHES (MM) 2. DIMENSIONS ARE TYPICAL		<b>Northern Technologies</b> THIS DRAWING IS THE PROPERTY OF NORTHERN TECHNOLOGIES AND SHOULD NOT BE REPRODUCED WITHOUT NORTHERN TECHNOLOGIES WRITTEN PERMISSION.		
DRAWN JSD		PART NUMBER SEE PART NUMBER INFORMATION		
20-MAR-05		DESCRIPTION CM 09 METAL COVER		
CHECKED SCN	20-MAR-05	SIZE B	CODE 200_101	DWG NO. 0002-200-101
ISSUED	20-MAR-05	SCALE N.T.S.		REV
				SHEET 1 OF 2

THIS IS A CONTROLLED DOCUMENT AND IS SUBJECT TO CHANGE. CONTACT NORTHERN TECHNOLOGIES ENGINEERING FOR THE LATEST REVISION.

**PART NUMBER INFORMATION**

PART#	WITH #4-40 X 1/2" CAPTIVE SCREWS (SLOT HEAD)	SUPPLIED
A29E821093	NO LOGO COVER TOP	BULK
A29E921090	NORTECH LOGO COVER TOP	BULK
A30E100100	COVER BOTTOM	BULK
C88E000209	NO LOGO	PACKAGED
C88E000218	NORTECH LOGO	PACKAGED

PART#	WITH #4-40 X 7/16" CAPTIVE SCREWS (SLOT HEAD)	SUPPLIED
A29E8210931	NO LOGO COVER TOP	BULK
A29E9210901	NORTECH LOGO COVER TOP	BULK
A30E100100	COVER BOTTOM	BULK
C88E0002091	NO LOGO	PACKAGED
C88E0002181	NORTECH LOGO	PACKAGED

PART#	WITH M2.5 X 12.7MM CAPTIVE SCREWS (SLOT HEAD)	SUPPLIED
A29E821093M25S	NO LOGO COVER TOP	BULK
A29E921090M25S	NORTECH LOGO COVER TOP	BULK
A30E100100	COVER BOTTOM	BULK
C88E000209M25S	NO LOGO	PACKAGED
C88E000218M25S	NORTECH LOGO	PACKAGED

PART#	WITH M2.6 X 12.7MM CAPTIVE SCREWS (SLOT HEAD)	SUPPLIED
A29E821093M26S	NO LOGO COVER TOP	BULK
A29E921090M26S	NORTECH LOGO COVER TOP	BULK
A30E100100	COVER BOTTOM	BULK
C88E000209M26S	NO LOGO	PACKAGED
C88E000218M26S	NORTECH LOGO	PACKAGED

PART#	WITH M3 X 12.7MM CAPTIVE SCREWS (SLOT HEAD)	SUPPLIED
A29E821093M3S	NO LOGO COVER TOP	BULK
A29E921090M3S	NORTECH LOGO COVER TOP	BULK
A30E100100	COVER BOTTOM	BULK
C88E000209M3S	NO LOGO	PACKAGED
C88E000218M3S	NORTECH LOGO	PACKAGED

PART#	WITH #4-40 X 1/2" CAPTIVE SCREWS (PHILLIPS HEAD)	SUPPLIED
A29E821093PS	NO LOGO COVER TOP	BULK
A29E921090PS	NORTECH LOGO COVER TOP	BULK
A30E100100	COVER BOTTOM	BULK
C88E000209PS	NO LOGO	PACKAGED
C88E000218PS	NORTECH LOGO	PACKAGED

REVISIONS				
ZONE	REV	DESCRIPTION	DATE	APPROVED

FILLISTER HEAD CAPTIVE SCREW

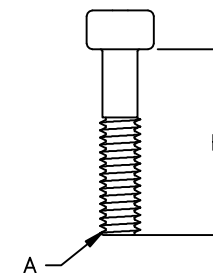

THREAD (A)	LENGTH (B)	HEAD STYLE	MATERIAL	PLATING
#4-40 UNC	1/2 INCH	SLOT	COLD ROLL STEEL	ZINC
#4-40 UNC	7/16 INCH	SLOT	COLD ROLL STEEL	ZINC
M2.5 X .45MM	12.7 MM	SLOT	LOW CARBON STEEL	ZINC
M2.6 X .45MM	12.7 MM	SLOT	LOW CARBON STEEL	ZINC
M3 X .5MM	12.7 MM	SLOT	LOW CARBON STEEL	ZINC
#4-40 UNC	1/2 INCH	PHILLIPS	LOW CARBON STEEL	ZINC

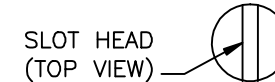

SLOT HEAD (TOP VIEW)



PHILLIPS HEAD (TOP VIEW)

THIS IS A CONTROLLED DOCUMENT AND IS SUBJECT TO CHANGE. CONTACT NORTHERN TECHNOLOGIES ENGINEERING FOR THE LATEST REVISION.

UNLESS OTHERWISE SPECIFIED 1. ALL DIMENSIONS ARE IN INCHES [MM] 2. DIMENSIONS ARE TYPICAL		<b>Northern Technologies</b> <small>THIS DRAWING IS THE PROPERTY OF NORTHERN TECHNOLOGIES AND SHOULD NOT BE REPRODUCED WITHOUT NORTHERN TECHNOLOGIES WRITTEN PERMISSION.</small>		
DRAWN JSD		PART NUMBER SEE PART NUMBER INFORMATION DESCRIPTION CM 09 METAL COVER		
20-MAR-05		SIZE B	CODE 200_101	DWG NO. 0002-200-101
CHECKED SCN	20-MAR-05	SCALE NTS		REV
ISSUED	20-MAR-05	SHEET 2 OF 2		